

■ **Kalesinterflex**
Ultimate Covering Material

■ **T-ONE**
Superior Porcelain Countertop

Interactive
CATALOGUE

■ **Kale**



INDEX



A COMPLETE
PRODUCT
SYSTEM



PRODUCT
FINDER



LOOK



COMPANY



KALESINTERFLEX



T-ONE



TECHNICAL
SPECIFICATIONS

INDEX





INDEX

A COMPLETE
PRODUCT
SYSTEM

PRODUCT
FINDER

LOOK

COMPANY

KALESINTERFLEX

T-ONE

TECHNICAL
SPECIFICATIONS

> **A COMPLETE
PRODUCT SYSTEM**

> **PRODUCT FINDER**

- Alphabetic Index

> **LOOK**

- Look Index

> **COMPANY**

- History
- Headquarters
- Flagships
- International Leadership
- Worldwide Projects
- Local Projects
- Sustainability
- Certificates

> **KALESINTERFLEX**

Collections

- Marble Look
- Stone Look
- Cement Look
- Metal Look
- Solid Color Look
- Design Collection

Spaces

- Bathrooms
- Kitchens
- Interior
- Exterior

Technology

- Decotech
- Bodytech
- Flowtech
- Openbook
- Glowtech
- V-Intech
- Formtech

> **T-ONE**

- T-One Porcelain Countertop
- Thicknesses - Sizes
- Features
- T-One In The Spotlight:
Chefs Share Their Thoughts
- Products

> **TECHNICAL
SPECIFICATIONS**

Kalesinterflex

- Thicknesses - Sizes
- Symbols
- Kaleguard Defence
- Services
- Size Table
- Packaging and Shipping Details
- Technical Characteristics

T-One

- Symbols
- Technical Specifications

Ultimate Covering Material: Kalesinterflex / A Complete Product System

Superior features, extensive areas of use.

Designed to shape the architecture of the future, Kalesinterflex, with its superior features, is much different than conventional ceramics. Due to its light and thin form, Kalesinterflex is an ideal choice for building exteriors, and its robust structure makes it resistant to different climate conditions. Its modern looks, large dimensions that reduce the number of grout lines, and vast range of colors make Kalesinterflex an indispensable part of any interior, adding value to life in various living areas including shopping centers, offices, subway stations, homes, and restaurants.

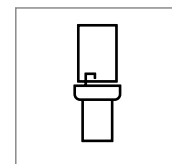

Bathrooms

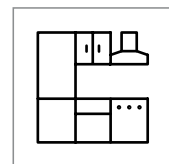

Kitchens

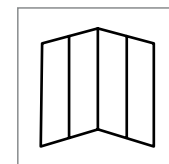

Interior

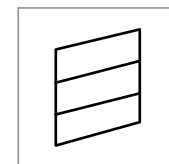

Exterior

The ultimate in ceramics.

An indispensable material used for unique architecture, ceramic introduces an entirely new look into modern lives with Kalesinterflex. Standing out with its lightweight, flexible form, ease of cutting and durable surface, Kalesinterflex goes beyond the conventional areas of use of ceramics. This special ceramic introduces a functional and minimalist use as it can be integrated into tables, bathrooms and kitchen counters, taking shape in accordance with the dreams of all professionals and decoration enthusiasts.

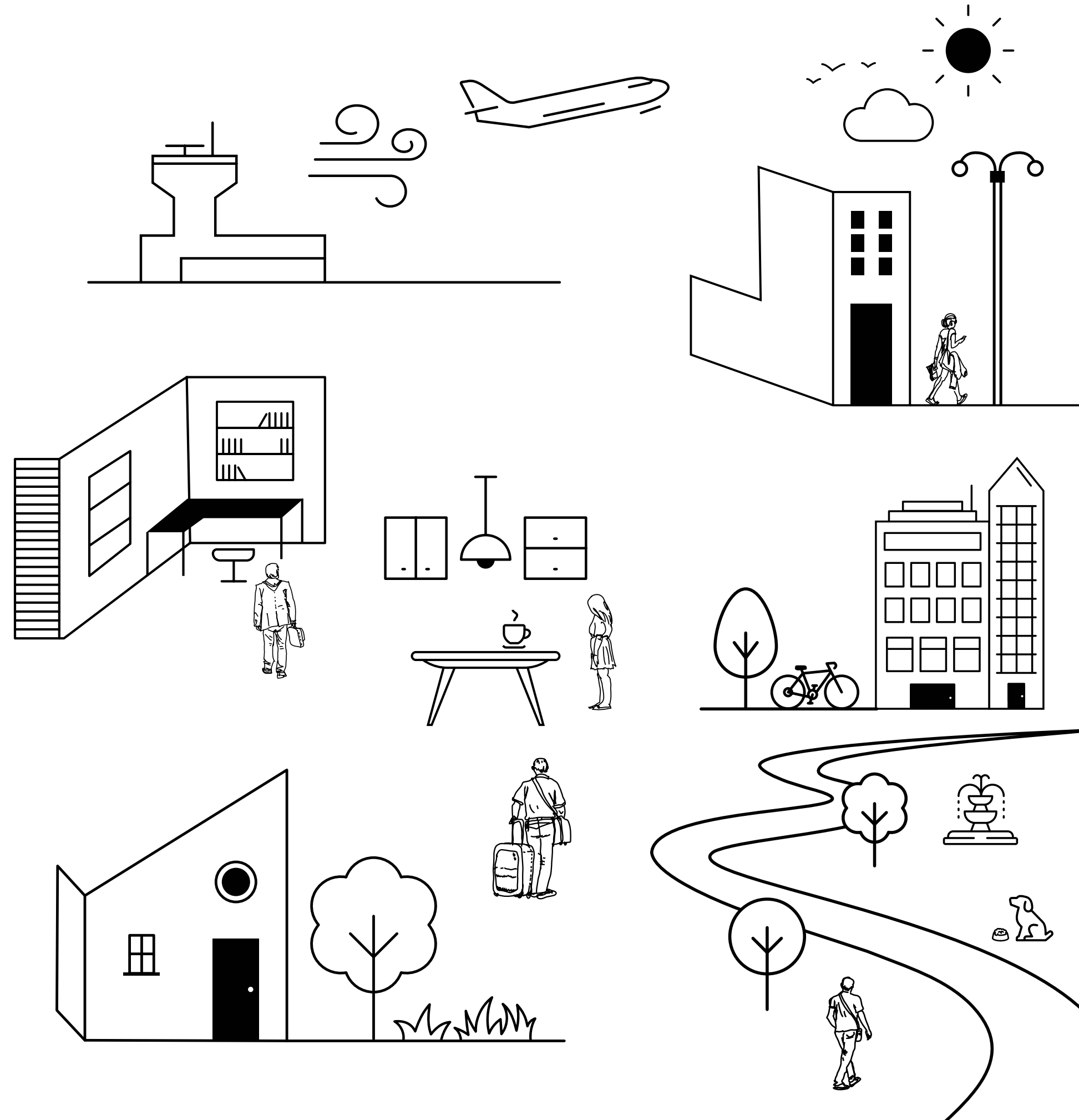



INDEX



A COMPLETE
PRODUCT
SYSTEM



PRODUCT
FINDER



LOOK



COMPANY



KALESINTERFLEX



T-ONE



TECHNICAL
SPECIFICATIONS



PRODUCT FINDER

> [Alphabetic Index](#)



INDEX

Alphabetic Index / Product Finder



A COMPLETE
PRODUCT
SYSTEM



PRODUCT
FINDER



LOOK



COMPANY



KALESINTERFLEX



T-ONE



TECHNICAL
SPECIFICATIONS

> Cement

LUXURY CEMENT

- Anthi
- Anthracite
- Beige
- Cement
- Grey
- Mink
- Taupe
- White

HUED

- Anthracite
- Dark Grey
- Grey
- Off White

HIGHWAY

- Bone

ARCHE

- Grey
- White

> Design Collection

- Coastal
- Color Dive
- Lueven
- Plain Spring
- Red Blossoms

> Marble Black & White

- Bronze Line
- Calacatta 2.0
- Calacatta Caldia
- Calacatta Gold
- Calacatta Ice
- Calacatta Macchia
- Calacatta Unique
- Calacatta Viola
- Colorado Oro Openbook
- Florence
- Golden Hour
- Limestone
- Marble Dark
- Palissandro
- Pietra Nero
- Port Laurent
- Statuario
- Winterland

> Marble Exclusive

- Sarrancolin
- Patagonia
- Quarzite J'adore
- Olimpo
- Marmo Metallo
- Alaska White
- Marina
- Versailles
- Sky
- Sahara Brown
- Alameda
- Asteroid
- Mocha Perla

> Marble Timeless

- Crystalus
- Denise
- Fiori Di Bosco
- Onice
- Pulpis
- Savana Dark
- Translucent

> Metallic

METALLIC

- Anthracite
- Coral

OXIDO

- Flame
- Ice
- Moss
- Oil



INDEX

Alphabetic Index / Product Finder

A COMPLETE
PRODUCT
SYSTEM



PRODUCT
FINDER



LOOK



COMPANY



KALESINTERFLEX



T-ONE



TECHNICAL
SPECIFICATIONS



> Solid Colors

INNOVATION

- Beige
- Beige-Grey
- Black
- Blue
- Brown
- Cement Grey
- Coral
- Dark Grey
- Mega Black
- Mega White
- Orange
- Pistachio Green
- White

LEDER

- Leder Brown

> Stone

NATURAL STONE

- Brera Creme
- Leccese Dark Sand
- Leccese Grey
- Leccese Light Sand
- Pietra Blue
- Pietra Grey

C-STONE

- Anthracite
- Beige
- Dark Brown
- Grey
- White

PIETRA

- Basaltina
- Chatillonn

OCEAN

- Black
- White

STONELAND

- Pietra Di Bone
- Pietra Di Gre

TERRAZZO

- Terrazzo

UPTOWN

- Dark
- Light

STONE GALLERY

- Quartz Ash

> Wood

WOODLINE

- Cherry
- Oak
- Walnut

HOLLYWOOD

- Beige
- Brown

SHELL WOOD

- Dark

PLANK

- BG 104
- BG 110
- BG 111
- BG 114

☰
INDEX

∨
A COMPLETE
PRODUCT
SYSTEM

∨
PRODUCT
FINDER

∨
LOOK

∨
COMPANY

∨
KALESINTERFLEX

∨
T-ONE

∨
TECHNICAL
SPECIFICATIONS

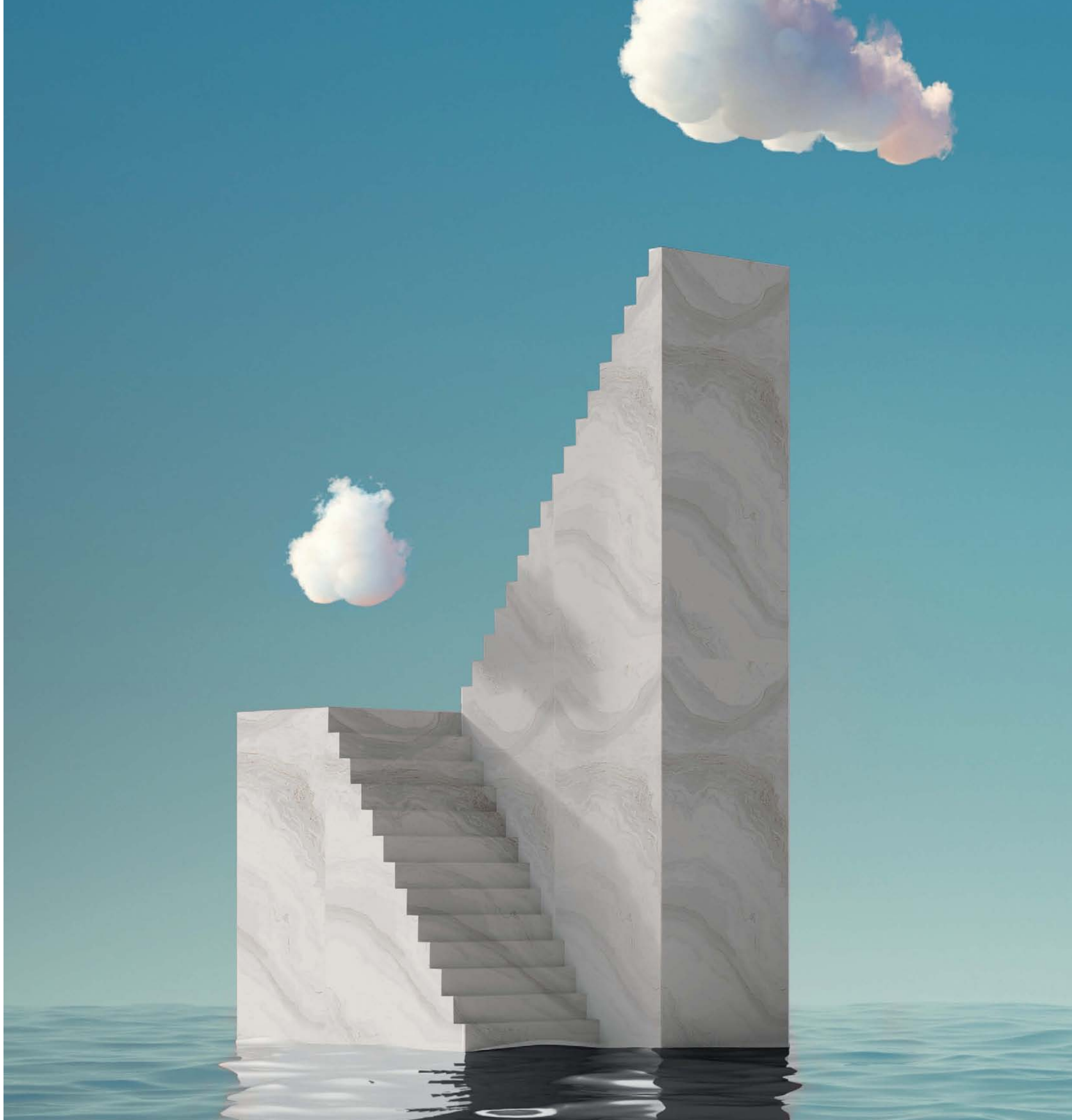

LOOK

> [Look Index](#)

Look Index / Look

SOLID COLORS

INNOVATION



MEGA WHITE WHITE BEIGE BEIGE-GREY CEMENT GREY DARK GREY



PISTACHIO GREEN ORANGE CORAL BLUE BROWN BLACK MEGA BLACK

LEDER



BROWN

MARBLE BLACK AND WHITE



STATUARIO CALACATTA CALDIA CALACATTA UNIQUE CALACATTA GOLD CALACATTA 2.0 BRONZE LINE PALISSANDRO



LIMESTONE CALACATTA ICE WINTERLAND GOLDEN HOUR CALACATTA VIOLA COLORADO ORO OPENBOOK



FLORENCE CALACATTA MACCHIA PIETRA NERO PORT LAURENT MARBLE DARK

MARBLE EXCLUSIVE



SARRANCOLIN PATAGONIA QUARZITE D'ADORE OLIMPO MARMO METALLO SAHARA BROWN ALAMEDA



ALASKA WHITE MARINA VERSAILLES SKY ASTEROID MOCHA PERLA

MARBLE TIMELESS



FIORI DI BOSCO CRYSTALLUS DENISE PULPIS SAVANA DARK TRANSLUCENT

CEMENT

LUXURY CEMENT



WHITE BEIGE GREY CEMENT OFF WHITE DARK GREY



TAUPE MINK ANTHRACITE ANTHI GREY ANTHRACITE

HIGHWAY



BONE

ARCHE



ARCHE WHITE ARCHE GREY

STONE

NATURAL STONE



LECCESE GREY LECCESE LIGHT SAND LECCESE DARK SAND PIETRA BLUE PIETRA GREY BRERA CREME

C-STONE



WHITE GREY BEIGE ANTHRACITE DARK BROWN PIETRA DI CHATILLONN PIETRA BASALTINA

OCEAN



WHITE BLACK

STONELAND



PIETRA DI BONE PIETRA DI GREY

TERRAZZO



TERRAZZO

UPTOWN



LIGHT DARK

STONE GALLERY



QUARTZ ASH

OMNITECH



MONOLITH PIEMONTE GREY

EARTH COLLECTION



TRAVERTINE SILVER RAPOLANO IVORY LIGHT TRAVERTINE IVORY

CALCARIO COLLECTION



CALCARIO CALCARIO LINE

METALLIC

METALLIC

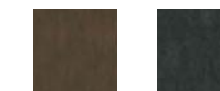

CORAL ANTHRACITE

OXIDO



ICE OIL MOSS FLAM

WOOD

HOLLYWOOD



BEIGE BROWN

WOODLINE



OAK WALNUT CHERRY

PLANK

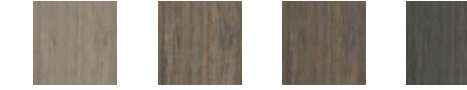

BG 104 BG 111 BG 110 BG 114 DARK

SHELL WOOD



DARK

DESIGN COLLECTION

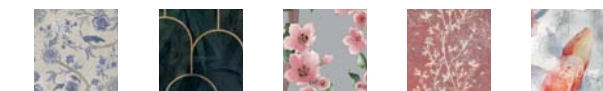

COASTAL LUEVEN PLAIN SPRING RED BLOSSOMS COLOR DIVE



INDEX



A COMPLETE
PRODUCT
SYSTEM



PRODUCT
FINDER



LOOK



COMPANY



KALESINTERFLEX



T-ONE



TECHNICAL
SPECIFICATIONS



COMPANY

- > History
- > Headquarters
- > Flagships
- > International Leadership
- > Worldwide Projects
- > Local Projects
- > Sustainability
- > Certificates

History / Company

Kaleseramik, which pioneered the establishment of the Turkish ceramics industry is a **66 - years** old value that produces and invests what it earns on these lands.

Çanakkale Seramik Fabrikaları A.Ş. (Çanakkale Ceramic Factories, Inc.) which is Turkey's first ceramic tile manufacturer, was founded in **1957**, and Kalebodur Seramik Sanayi A.Ş. (Kalebodur Ceramic Industry, Inc.) which is Turkey's first floor tile manufacturer, was founded in **1972**.

Maintaining its production with Çanakkale Ceramic and Kalebodur brands, Kaleseramik is the world's largest ceramic company producing in a single area with a production capacity of **56 million square meters per year**. Experience a legacy that spans **66 years**, as Kaleseramik emerges as an unrivaled pioneer in Anatolia's industrial tapestry. Holding the distinction of being the premier and **18th largest ceramic producer in Turkey and the global arena**, Kaleseramik has set an unprecedented benchmark in the ceramics domain.

Nestled in the heart of Çan, our production hub sprawls over an expansive canvas of **1.25 million square meters outdoors and 650,000 square meters indoors**. This extensive framework fuels an exceptional production capacity, boasting **26.3 million square meters of wall tiles, 28.1 million square meters of floor tiles, 5.5 million square meters of granite ceramics, and 1.8 million square meters of Kalesinterflex per annum**.

Diversity thrives within our creations, presenting an array of **1,900 distinct floor tile designs spanning across 50 sizes, alongside 2,200 wall tile variations adorning 60 different dimensions**. Guided by our unwavering commitment to innovation, we unveil approximately **200 new product categories** each year, enthraling consumers with novel offerings.





INDEX



A COMPLETE PRODUCT SYSTEM



PRODUCT FINDER



LOOK



COMPANY



KALESINTERFLEX



T-ONE



TECHNICAL SPECIFICATIONS

History / Company

Behold the visionary Kalesinterflex porcelain slab, conceptualized in **2005** through Kaleseramik's unparalleled expertise. A pioneering marvel redefining porcelain slabs, it merges sprawling dimensions, graceful profiles, lightweight compositions, and ecologically mindful production, heralding a new era of possibilities.

In 2023, a groundbreaking investment births a revitalized Kalesinterflex, featuring dimensions spanning **160x320cm, graced by 6mm, 12mm, and 20mm thickness options. Matte, satin, and polished surface finishes await, poised to revolutionize architectural paradigms.**

Welcome to Kaleseramik, where heritage converges with innovation, and ceramics metamorphose into artistry. Embark with us on a journey to shape the future of sophisticated spaces, driven by technology and refinement.

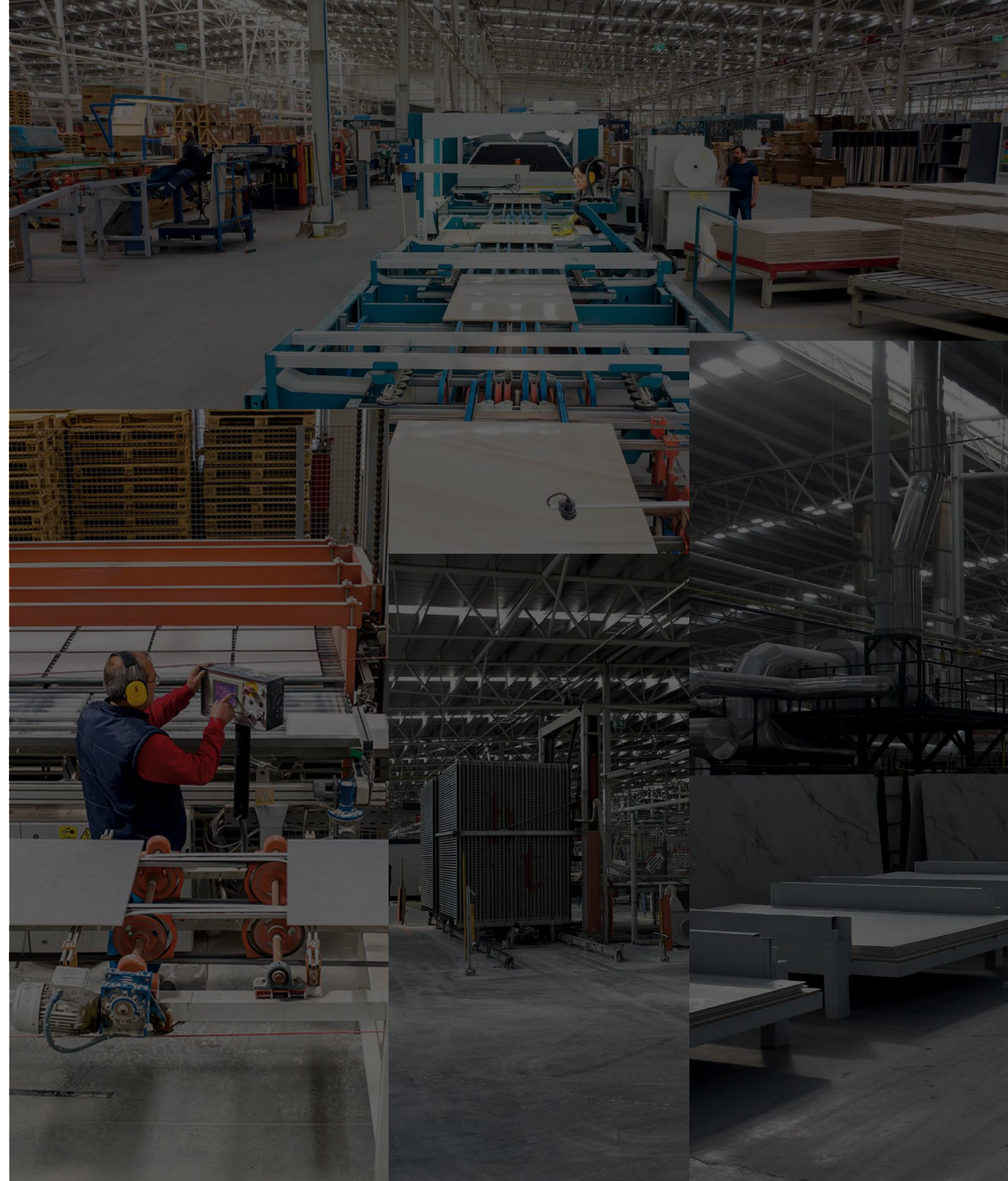



INDEX



A COMPLETE
PRODUCT
SYSTEM



PRODUCT
FINDER



LOOK



COMPANY



KALESINTERFLEX



T-ONE



TECHNICAL
SPECIFICATIONS

Headquarters / Company

KALE. LEADER IN TURKEY, PIONEER IN THE WORLD.

85+ countries, **160+** points of sale In Turkey.

530+ different sales points in total, including **123** exclusive dealers, **193** subdealers, **6** Kale Showrooms, and **55** building supply stores.

Part of the Kale Group, comprised of **20 leading companies** operating in the Building Materials, Chemicals, Mining, Transportation, Aerospace and Defense industries

Ranks 5th in Europe, 18th in the World in terms of ceramic production capacity

First ceramic tile factory in Turkey

First wall, floor and porcelain tile productions in Turkey

First company in the world to invest in and begin production with the **Kalesinterflex technology**

First wall tile export from Turkey

First Turkish company in the construction industry to receive an **EPD certificate** for all product groups

First Turkish company to receive the **ISO 17025 Laboratory Adequacy Certificate for technical ceramics**

The first company in Turkey to receive **HDP certification for wall tiles.**



INDEX



A COMPLETE
PRODUCT
SYSTEM



PRODUCT
FINDER



LOOK



COMPANY



KALESINTERFLEX



T-ONE



TECHNICAL
SPECIFICATIONS

Flagships / Company

Our spaces in the most important capital of design



— Çeşme Showroom, İzmir



— İzmir Showroom, İzmir

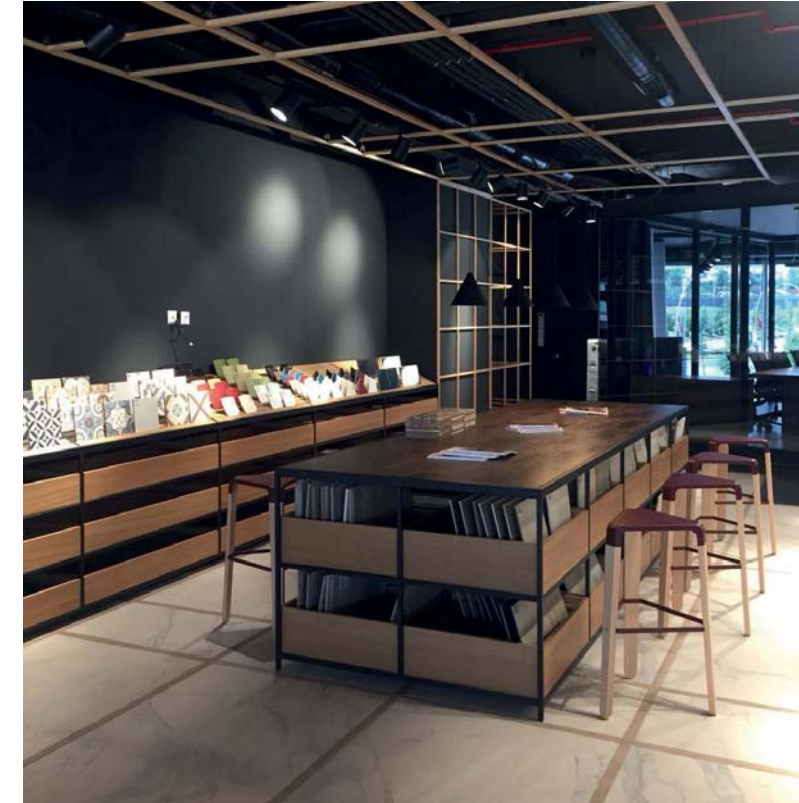

— Ankara Showroom, Ankara



— Fulya Showroom, İstanbul



— Kozyatağı Showroom, İstanbul



— Levent Showroom, İstanbul

International Leadership / Company

Exports to
more than
85+
countries



- INDEX
- A COMPLETE PRODUCT SYSTEM
- PRODUCT FINDER
- LOOK
- COMPANY
- KALESINTERFLEX
- T-ONE
- TECHNICAL SPECIFICATIONS



INDEX

A COMPLETE
PRODUCT
SYSTEM

PRODUCT
FINDER

LOOK

COMPANY

KALESINTERFLEX

T-ONE

TECHNICAL
SPECIFICATIONS

Worldwide Projects / Company



— South Korea, Atomy Headquarter



— Australia, Wattle Avenue House



— Pakistan, Tapal Head Office



— South Korea, Sejong City M-Bridge



— Spain, Barsezona Metro Station

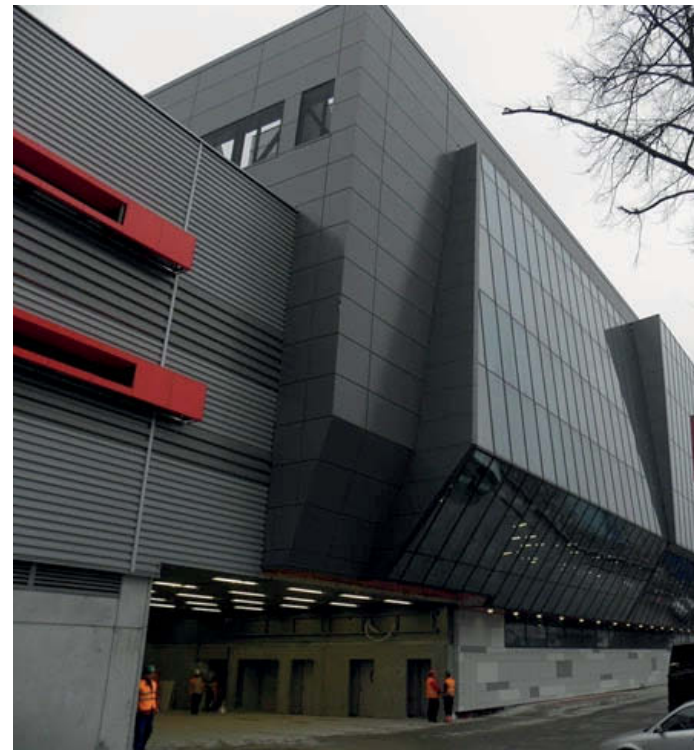

— Slovakia, Winter Stadium



— Libya, Cornivius University



— Italy, Impianto Crematorio di Copparo



INDEX

Local Projects / Company

A COMPLETE
PRODUCT
SYSTEM

PRODUCT
FINDER

LOOK

COMPANY

KALESINTERFLEX

T-ONE

TECHNICAL
SPECIFICATIONS



— İstanbul, Neolokal Restaurant



— İstanbul, Zorlu Center Mall



— İstanbul, Koç University Hospital



— İstanbul, Neva Garden Residential Project



— İstanbul, Sev College



— Ankara, Mutlu Koru Residential Project

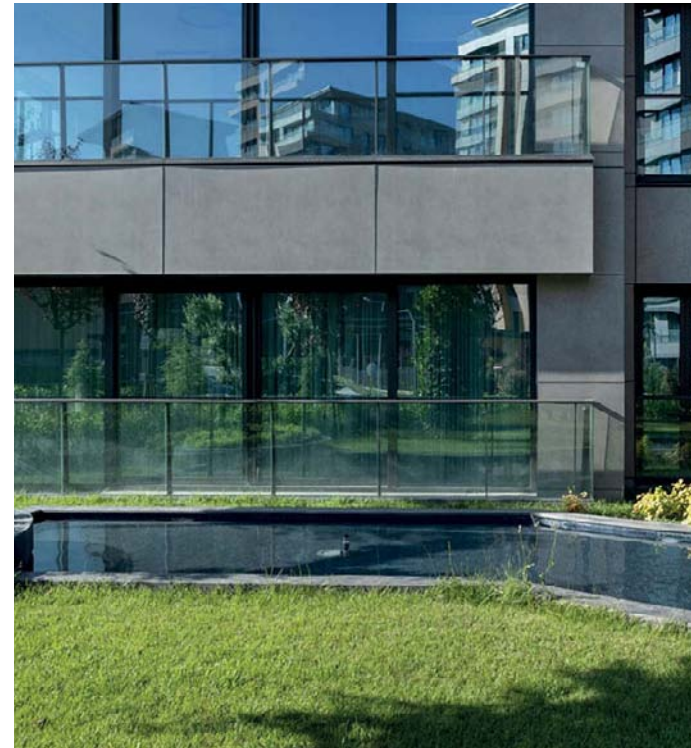

— İstanbul, Vadi İstanbul Residential Project

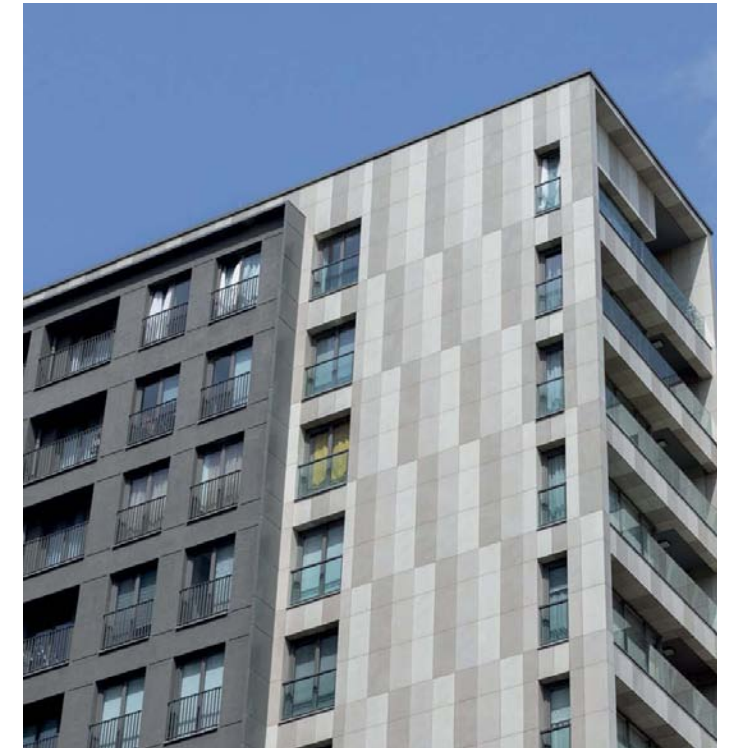

— İstanbul, Mesa Cadde Residential Project



INDEX



A COMPLETE
PRODUCT
SYSTEM



PRODUCT
FINDER



LOOK



COMPANY



KALESINTERFLEX



T-ONE



TECHNICAL
SPECIFICATIONS

Sustainability / Company

At Kaleseramik, we prioritize investing in impact-driven circular projects for a sustainable future. Advocating that everyone has a responsibility for a fairer, more equitable, and greener world, we aim to create conscious awareness and inspire action towards it.

With this awareness in mind, we have chosen to introspect and reflect on the days we live in as a phase of mindfulness. Rooted not in problems but in the sensitivity of nourishing responsibility, our approach of "**Care for Your World**" is a belief that the small changes we initiate in our own worlds will unite into a powerful movement.

Today, every individual holds the potential to make a difference – starting from themselves, their habits, their homes, their streets, neighborhoods, cities, countries, and ultimately the planet. At Kaleseramik, we continue to closely follow the local and global sustainability agenda and work to bring new meanings to living spaces.



WATCH THE VIDEO



WE ARE READY TO
TAKE CARE OF YOUR
HOME, YOUR WORLD,
AND YOU...



INDEX



A COMPLETE
PRODUCT
SYSTEM



PRODUCT
FINDER



LOOK



COMPANY



KALESINTERFLEX



T-ONE



TECHNICAL
SPECIFICATIONS

Sustainability / Company

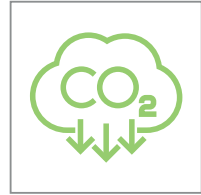

Greenhouse Gas Emissions and Energy Management

We, as Kaleseramik, attach great importance to meticulously managing our environmental impact and reducing carbon emissions generated from our activities. In line with our future commitments, we aim to reduce direct greenhouse gas emissions **by 25% from 2021 to 2030**. Thanks to our efforts in energy management, we intend to generate

100% of the electricity we will use by

2030 from renewable energy sources.
We are taking our steps decisively for a sustainable future.

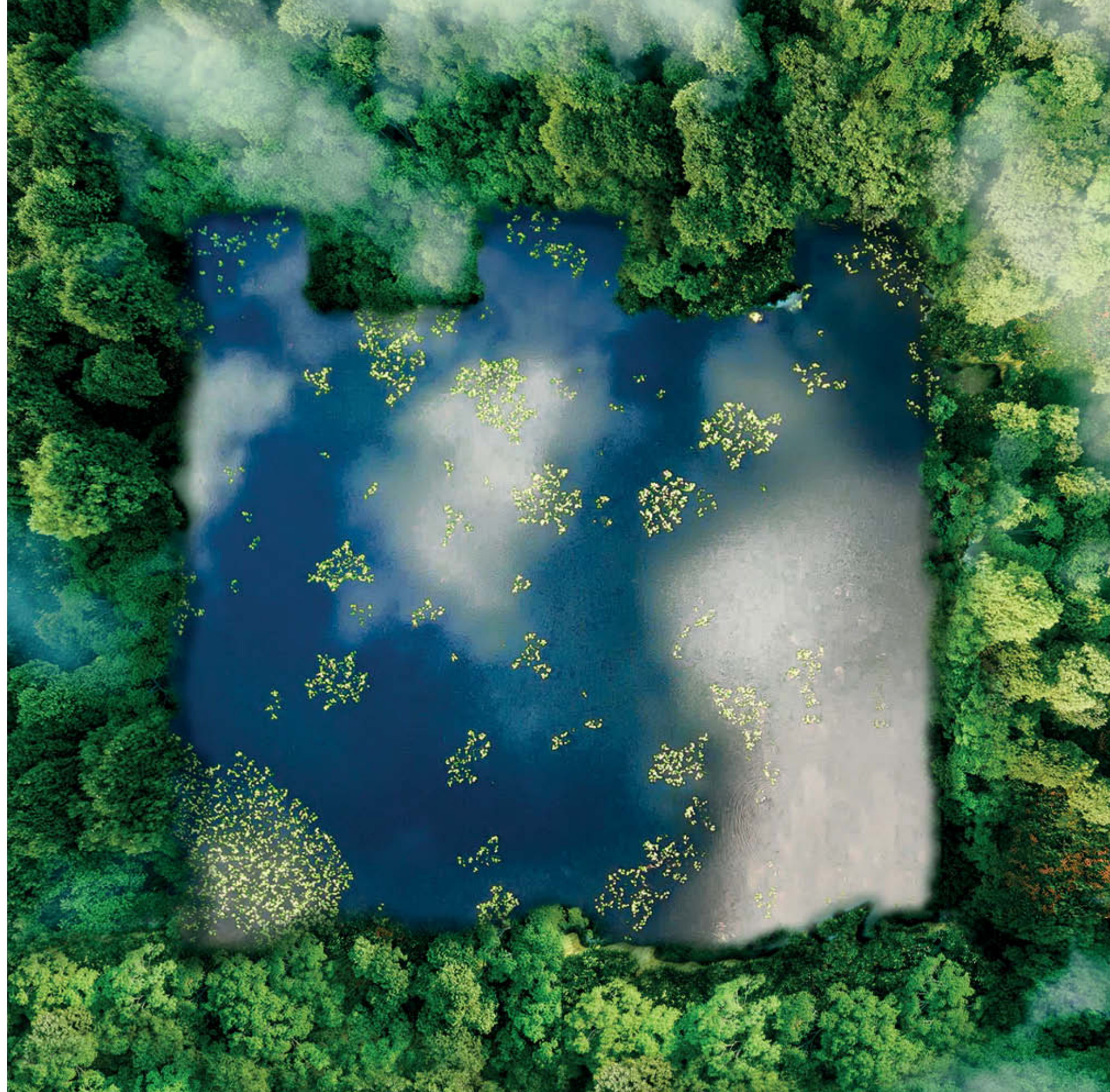

Sustainability / Company



An Exemplary Circular Economy in which Waste Heat is Used in a Greenhouse Facility

As a reflection of our approach regarding sustainability, we attach importance to utilizing waste heat generated in the ceramic sludge preparation facilities of our factories. Through our innovative approach, we use the waste heat from the ceramic sludge preparation facilities to heat the modern greenhouse facility of Mavruz Tarım. Thanks to the **9,557-meter-long line** established within the project, we transmit water between the factory and the greenhouse facility in a closed cycle. Meeting the heat needs of the greenhouse, we minimize fuel use and contribute to the reduction of **2,546 tons of CO₂ emissions per year on average.**

We care for the world with our successful project, which won the Special Jury

Award in the Energy Efficiency

category at the Istanbul Chamber of Industry Green Transformation Awards in 2022.



Circular Economy and Waste Management

We are aiming to increase our closed-loop production rate by

100% until 2030,

and we are constantly working to fulfill our future commitments.



- INDEX
- A COMPLETE PRODUCT SYSTEM
- PRODUCT FINDER
- LOOK
- COMPANY
- KALESINTERFLEX
- T-ONE
- TECHNICAL SPECIFICATIONS

Sustainability / Company

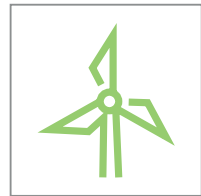

Sustainable Products and Green Innovation

We focus on innovation with our sustainability mission and ESG goals. We take environmentally friendly steps in every field, from our products to our operations, from our facilities to our business models, and we design **a sustainable ecosystem with the technologies and integrated systems we have developed.**



Kaleseramik Green Product Guide

Through the Green Product Guide we published, we comprehensively highlight the use of our products in sustainable buildings.

We have provided an important resource for the design and implementation stages of sustainable structures with the guide highlighting the requirements of green building rating systems including **LEED v4-v4.1, BREEAM, DGNB, and BEST.**

[The Green Product Guide](#)



DGNB BREEAM®



INDEX



A COMPLETE
PRODUCT
SYSTEM



PRODUCT
FINDER



LOOK



COMPANY



KALESINTERFLEX



T-ONE



TECHNICAL
SPECIFICATIONS

Sustainability / Company



Kalesinterflex

Thanks to the Kalesinterflex Porcelain Slab, which was designed with sustainable production technologies as one of the special materials of architecture, we offer functional and environmentally friendly solutions.

Compared to standard ceramics, we are producing a slab that enables;

Raw Material Consumption:

Compared to standard ceramic tiles,

57% less

Water Consumption:

Compared to standard ceramic tiles,

20% less

Natural Gas Consumption:

Compared to standard ceramic tiles,

47% less

Logistics:

Compared to standard ceramic tiles,

90%

more products can be transported in a container.



Sustainability / Company



Cura Tile / We care for your health and the world.

With Cura Tile, which was designed to improve the health of people and nature, we are creating a new generation of ceramic tiles, which are unique in the world.

Today, when the importance of indoor air quality is increasing, we are offering healthy and safe breath for users. Through furnace-less production technology, we use

70%
and

62%

less greenhouse gas emissions than conventional ceramics.

We protect our energy by reducing the need for air conditioning in the environment with Cura Tile, which cleans the air in living spaces from bacteria and viruses and provides a comfortable breathing opportunity with its porous surface.

With Cura Tile, designed by the Kale patent in line with the **New European Bauhaus and the United Nations Sustainable Development Goals, we create innovative and sustainable solutions for our world.**

[Cura Tile Website](#)



INDEX

A COMPLETE
PRODUCT
SYSTEM

PRODUCT
FINDER

LOOK

COMPANY

KALESINTERFLEX

T-ONE

TECHNICAL
SPECIFICATIONS

Sustainability / Company

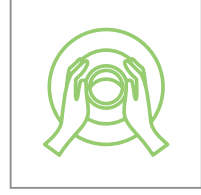

Atölye Kale

With Atölye Kale, which combines the art of ceramics coming from history and a unique craft, we prepare tableware, souvenir and original tile designs for different living spaces with women's labor.

We carry out projects that leave marks on history with the handmade ceramic tiles giving life to the Red Globe at the heart of Atatürk Cultural Center, one of the iconic buildings, which brings Turkey's culture and art world together.

While increasing women's employment with Atölye Kale, which has designed personalized products,

**we support
the education
of girls with
the income
obtained.**

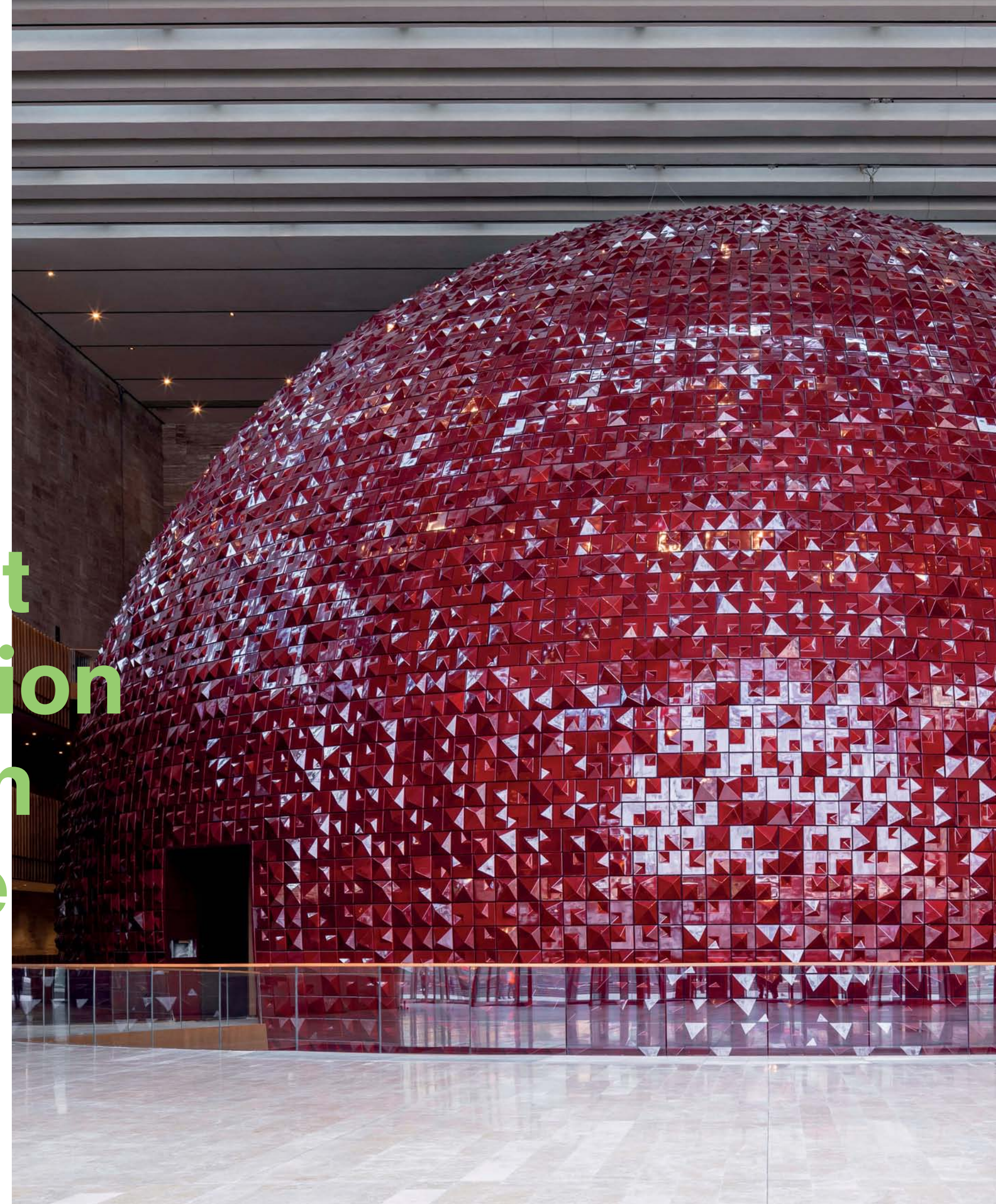



INDEX

A COMPLETE
PRODUCT
SYSTEM

PRODUCT
FINDER

LOOK

COMPANY

KALESINTERFLEX

T-ONE

TECHNICAL
SPECIFICATIONS

Sustainability / Company

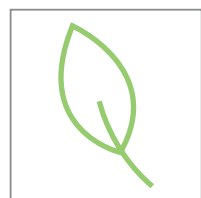

Horizon Europe Clean Hydrogen Partnership

We are proud to be part of the Horizon Europe Program supported by the European Union to accelerate scientific developments, increase employment potential, and create solutions to global problems such as the climate crisis.

Through the South Marmara Hydrogen Shore consortium established **by 16 companies** to gradually eliminate the use of fossil fuels in the industry and to decarbonize the sector, we aim to support the development of the hydrogen economy in our Kaleseramik factory and reveal the potential impact.

We aim to use hydrogen as a hybrid fuel in the sintering processes of ceramic tiles with hydrogen combustion systems that will partially replace the natural gas used in furnaces.

Cooperating with large companies in Turkey, we assume a leading role in supporting

**environmentally
friendly
technologies.**





INDEX

A COMPLETE
PRODUCT
SYSTEM

PRODUCT
FINDER

LOOK

COMPANY

KALESINTERFLEX

T-ONE

TECHNICAL
SPECIFICATIONS

Certificates / Company

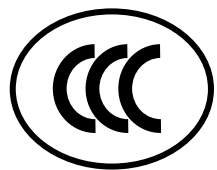
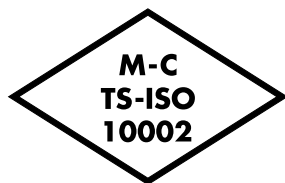

☰
INDEX

▼
A COMPLETE
PRODUCT
SYSTEM

▼
PRODUCT
FINDER

▼
LOOK

▼
COMPANY

▼
KALESINTERFLEX

▼
T-ONE

▼
TECHNICAL
SPECIFICATIONS



 **Kalesinterflex**
Ultimate Covering Material

 WATCH THE VIDEO

Kalesinterflex

> Collections

- Marble Look
- Stone Look
- Cement Look
- Metal Look
- Solid Color Look
- Design Collection

> Technology

- Decotech
- Bodytech
- Flowtech
- Openbook
- Glowtech
- V-Intech
- Formtech

> Spaces

- Bathrooms
- Kitchens
- Interior
- Exterior



- INDEX
- A COMPLETE PRODUCT SYSTEM
- PRODUCT FINDER
- LOOK
- COMPANY
- KALESINTERFLEX
- T-ONE
- TECHNICAL SPECIFICATIONS

Collections / Kalesinterflex

MARBLE LOOK

STONE LOOK

CEMENT LOOK

SOLID COLOR LOOK

METAL LOOK

DESIGN COLLECTION

Solid Colors



INNOVATION MEGA WHITE

	mm	Matte	Soft Matte	Polished	Satin
100x300 cm	3	•			
120x360 cm	3	•			
6					
160x320 cm	12		•		
20					
80x280 cm	6				

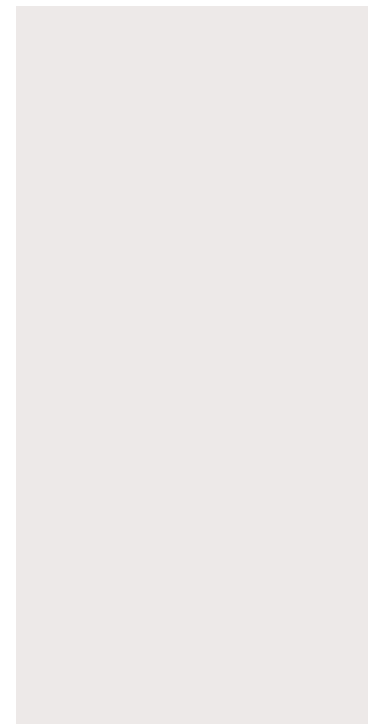

INNOVATION WHITE

	mm	Matte	Soft Matte	Polished	Satin
100x300 cm	3	•			
120x360 cm	3				
6					
160x320 cm	12		•		
20					
80x280 cm	6				

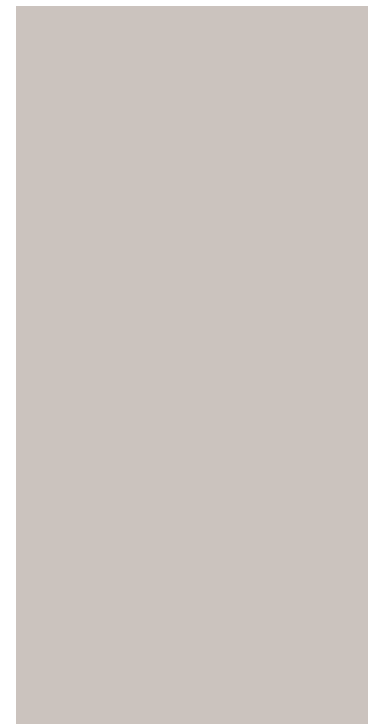

INNOVATION BEIGE

	mm	Matte	Soft Matte	Polished	Satin
100x300 cm	3	•			
120x360 cm	3				
6					
160x320 cm	12				
20					
80x280 cm	6				



INNOVATION BEIGE-GREY

	mm	Matte	Soft Matte	Polished	Satin
100x300 cm	3	•			
120x360 cm	3				
6					
160x320 cm	12				
20					
80x280 cm	6				



INNOVATION CEMENT GREY

	mm	Matte	Soft Matte	Polished	Satin
100x300 cm	3	•			
120x360 cm	3				
6					
160x320 cm	12				
20					
80x280 cm	6				



INNOVATION PISTACHIO GREEN

	mm	Matte	Soft Matte	Polished	Satin
100x300 cm	3	•			
120x360 cm	3				
6					
160x320 cm	12				
20					
80x280 cm	6				

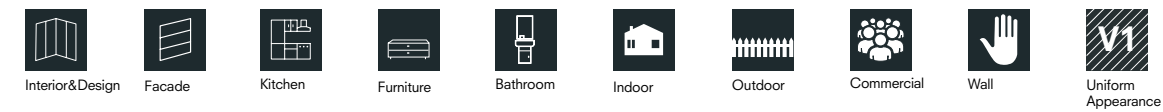

Solid Colors

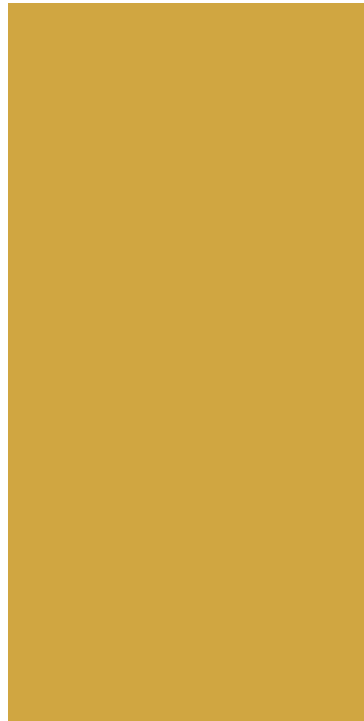

INNOVATION ORANGE

	mm	Matte	Soft Matte	Polished	Satin
100x300 cm	3	•			
120x360 cm	3				
	6				
160x320 cm	12				
	20				
80x280 cm	6				



INNOVATION CORAL

	mm	Matte	Soft Matte	Polished	Satin
100x300 cm	3	•			
120x360 cm	3				
	6				
160x320 cm	12				
	20				
80x280 cm	6				



INNOVATION BLUE

	mm	Matte	Soft Matte	Polished	Satin
100x300 cm	3	•			
120x360 cm	3				
	6				
160x320 cm	12				
	20				
80x280 cm	6				



Interior&Design



Facade



Kitchen



Furniture



Bathroom



Indoor



Outdoor



Commercial



Wall



Uniform Appearance

Solid Colors



INNOVATION BROWN

	mm	Matte	Soft Matte	Polished	Satin
100x300 cm	3	•			
120x360 cm	3				
160x320 cm	6				
	12				
	20				
80x280 cm	6				

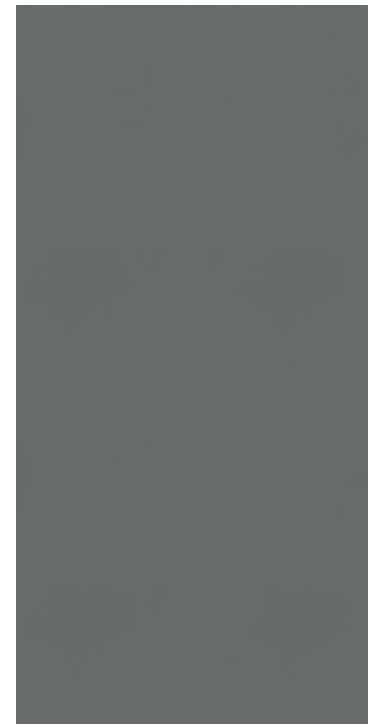

INNOVATION DARK GREY

	mm	Matte	Soft Matte	Polished	Satin
100x300 cm	3	•			
120x360 cm	3				
160x320 cm	6				
	12				
	20				
80x280 cm	6				



INNOVATION BLACK

	mm	Matte	Soft Matte	Polished	Satin
100x300 cm	3	•			
120x360 cm	3				
160x320 cm	6				
	12		•		
	20				
80x280 cm	6				



INNOVATION MEGA BLACK

	mm	Matte	Soft Matte	Polished	Satin
100x300 cm	3	•			
120x360 cm	3				
160x320 cm	6				
	12				
	20				
162x323 cm	12				
	20				



LEDER BROWN

	mm	Matte	Soft Matte	Polished	Satin
100x300 cm	3	•			
120x360 cm	3				
160x320 cm	6				
	12				
	20				
80x280 cm	6				

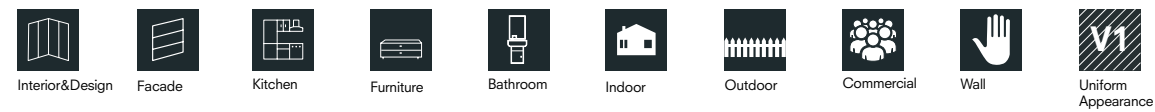

Marble Black and White



STATUARIO

	mm	Matte	Soft Matte	Polished	Satin
100x300 cm	3				
120x360 cm	3				
160x320 cm	6		•	•	
	12				
	20				
80x280 cm	6				

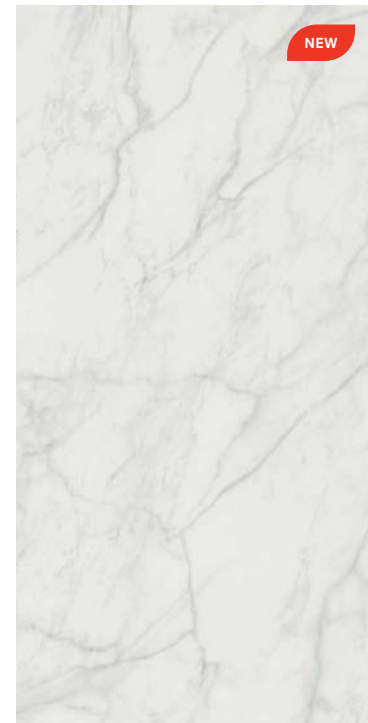

CALACATTA CALDIA

	mm	Matte	Soft Matte	Polished	Satin
100x300 cm	3	•			
120x360 cm	3	•			
160x320 cm	6		•	•	
	12		•	•	•
	20				
80x280 cm	6				

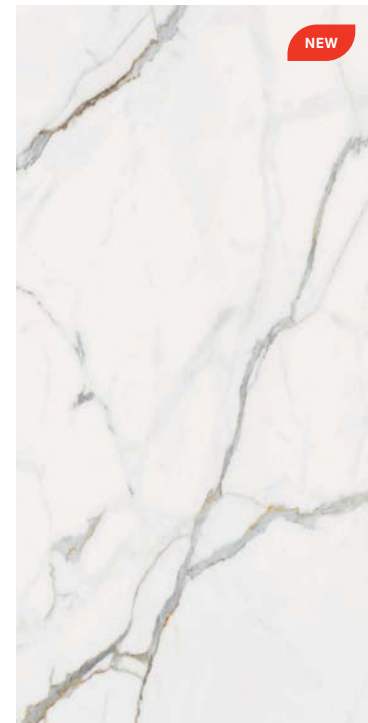

CALACATTA UNIQUE

	mm	Matte	Soft Matte	Polished	Satin
100x300 cm	3	•			
120x360 cm	3	•			
160x320 cm	6		•	•	
	12		•	•	•
	20				
80x280 cm	6				

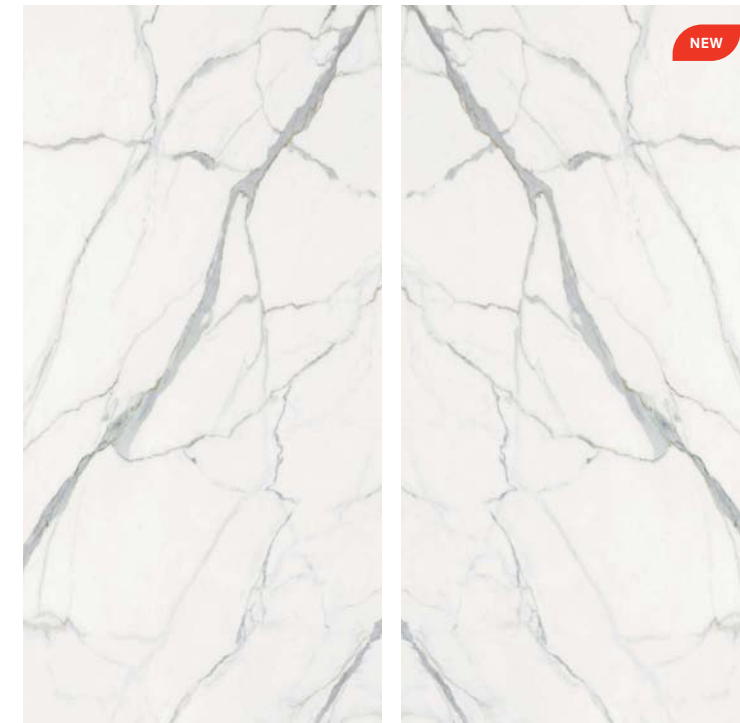

CALACATTA UNIQUE OPENBOOK

	mm	Matte	Soft Matte	Polished	Satin
100x300 cm	3	•			
120x360 cm	3	•			
160x320 cm	6			•	
	12			•	
	20				
80x280 cm	6				



CALACATTA GOLD*

	mm	Matte	Soft Matte	Polished	Satin
100x300 cm	3	•			
120x360 cm	3	•			
160x320 cm	6		•	•	
	12		•	•	
	20				
80x280 cm	6				

 *Glazing Surface: Regional shiny / sparkle effect on matte surface.

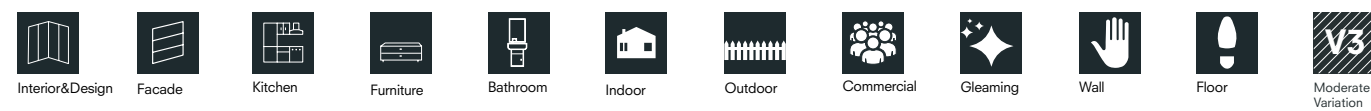

 *Glazing Surface: Regional shiny / sparkle effect on matte surface.



Marble Black and White



CALACATTA 2.0

	mm	Matte	Soft Matte	Polished	Satin
100x300 cm	3	•			
120x360 cm	3	•			
160x320 cm	6				
	12				
	20				
80x280 cm	6				



BRONZE LINE

	mm	Matte	Soft Matte	Polished	Satin
100x300 cm	3				
120x360 cm	3				
160x320 cm	6		•	•	
	12				
	20				
80x280 cm	6				



PALISSANDRO*

	mm	Matte	Soft Matte	Polished	Satin
100x300 cm	3	•			
120x360 cm	3	•			
160x320 cm	6		•		
	12		•		
	20				
80x280 cm	6				



GOLDEN HOUR

	mm	Matte	Soft Matte	Polished	Satin
100x300 cm	3				
120x360 cm	3				
160x320 cm	6		•	•	
	12				
	20				
80x280 cm	6				

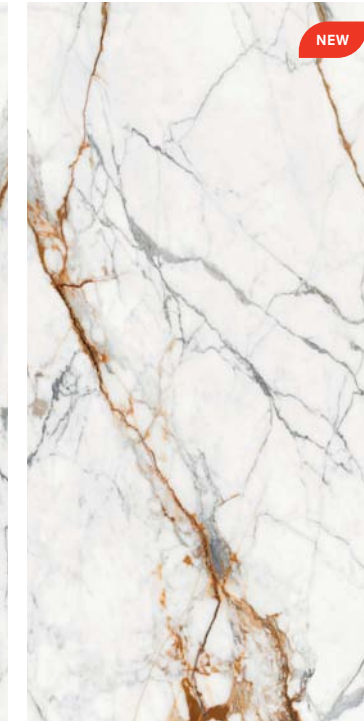

GOLDEN HOUR OPENBOOK

	mm	Matte	Soft Matte	Polished	Satin
100x300 cm	3				
120x360 cm	3				
160x320 cm	6		•	•	
	12				
	20				
80x280 cm	6				

*Gleaming Surface: Regional shiny / sparkle effect on matte surface.

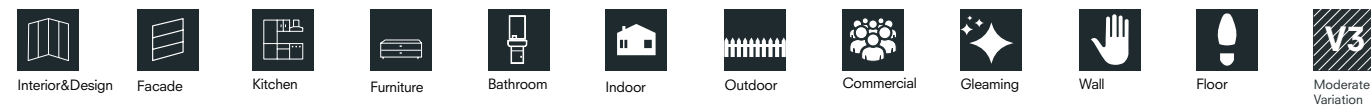

*Gleaming Surface: Regional shiny / sparkle effect on matte surface.

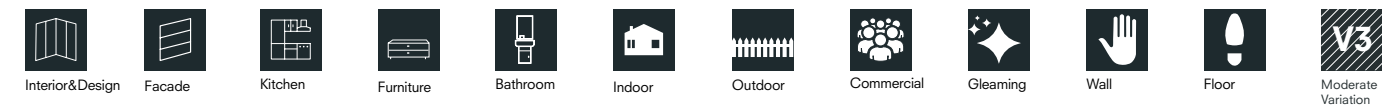

Marble Black and White



LIMESTONE

	mm	Matte	Soft Matte	Polished	Satin
100x300 cm	3	•			
120x360 cm	3	•			
160x320 cm	6				
	12				
	20				
80x280 cm	6				



CALACATTA ICE

	mm	Matte	Soft Matte	Polished	Satin
100x300 cm	3	•			
120x360 cm	3	•			
160x320 cm	6				
	12				
	20				
80x280 cm	6				



WINTERLAND*

	mm	Matte	Soft Matte	Polished	Satin
100x300 cm	3	•			
120x360 cm	3	•			
160x320 cm	6				
	12				
	20				
80x280 cm	6				



CALACATTA MACCHIA

	mm	Matte	Soft Matte	Polished	Satin
100x300 cm	3				
120x360 cm	3				
160x320 cm	6		•	•	
	12		•	•	
	20				
80x280 cm	6				



CALACATTA VIOLA

	mm	Matte	Soft Matte	Polished	Satin
100x300 cm	3				
120x360 cm	3				
160x320 cm	6		•	•	
	12		•	•	
	20				
80x280 cm	6				

 *Glazing Surface: Regional shiny / sparkle effect on matte surface.

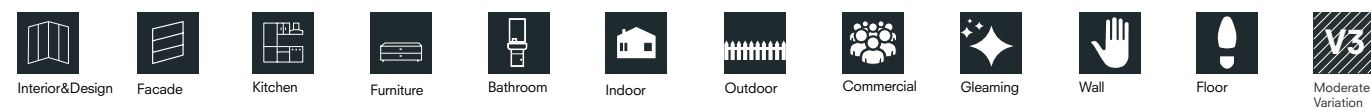

 *Glazing Surface: Regional shiny / sparkle effect on matte surface.



Marble Black and White



COLORADO ORO OPENBOOK

	mm	Matte	Soft Matte	Polished	Satin
100x300 cm	3	•			
120x360 cm	3				
160x320 cm	6				
	12				
162x323 cm	6				
	12				
	20				



FLORENCE

	mm	Matte	Soft Matte	Polished	Satin
100x300 cm	3				
120x360 cm	3				
160x320 cm	6		•	•	
	12		•	•	
80x280 cm	6				

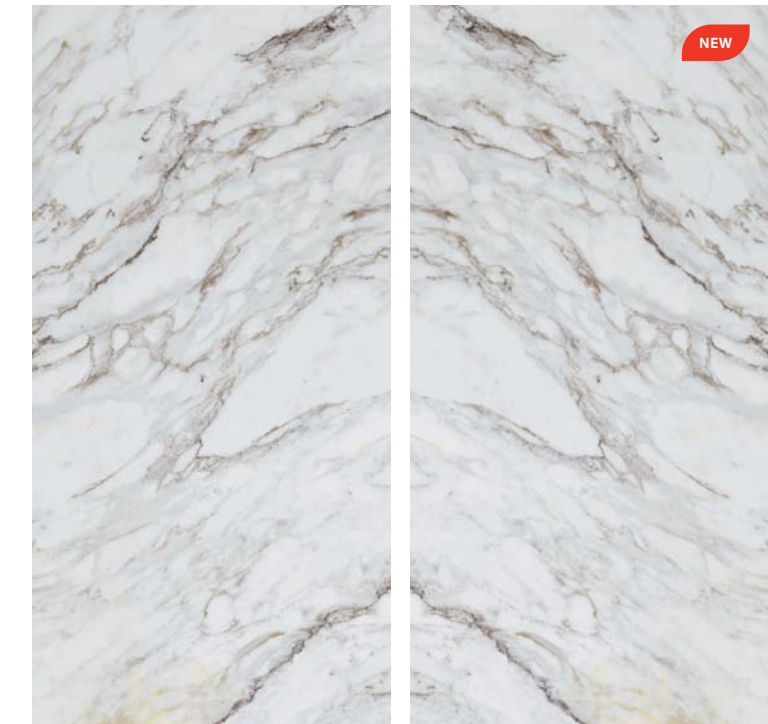

FLORENCE OPENBOOK

	mm	Matte	Soft Matte	Polished	Satin
100x300 cm	3				
120x360 cm	3				
160x320 cm	6		•	•	
	12		•	•	
80x280 cm	6				

✦ *Gleaming Surface: Regional shiny / sparkle effect on matte surface.

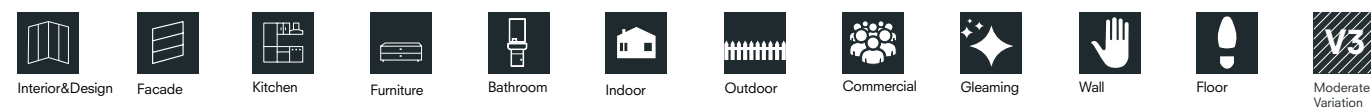

✦ *Gleaming Surface: Regional shiny / sparkle effect on matte surface.



Marble Black and White



PIETRA NERO

mm	Matte	Soft Matte	Polished	Satin
100x300 cm	•			
120x360 cm	•			
6		•	•	
120x320 cm		•	•	
12				
20				
80x280 cm				
6				

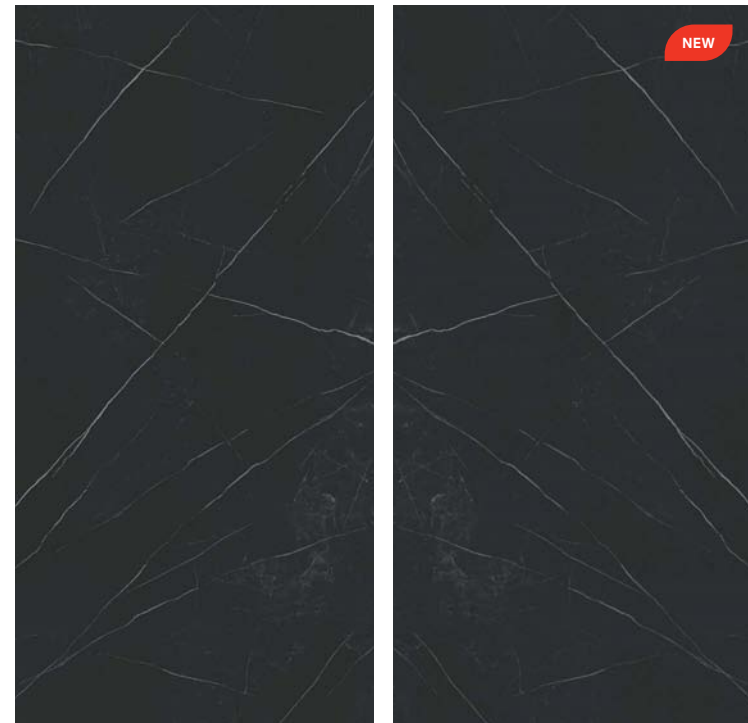

PIETRA NERO OPENBOOK

mm	Matte	Soft Matte	Polished	Satin
100x300 cm	•			
120x360 cm	•			
6		•	•	
120x320 cm		•	•	
12				
20				
80x280 cm				
6				

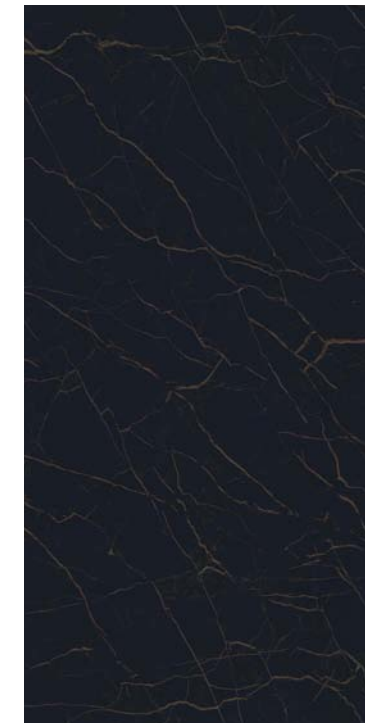

PORT LAURENT

mm	Matte	Soft Matte	Polished	Satin
100x300 cm	•			
120x360 cm				
6		•	•	
120x320 cm		•	•	
12				
20				
80x280 cm				
6				



MARBLE DARK

mm	Matte	Soft Matte	Polished	Satin
100x300 cm	•			
120x360 cm	•			
6				
120x320 cm				
12				
20				
80x280 cm				
6				

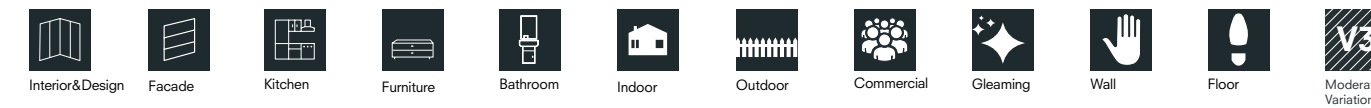
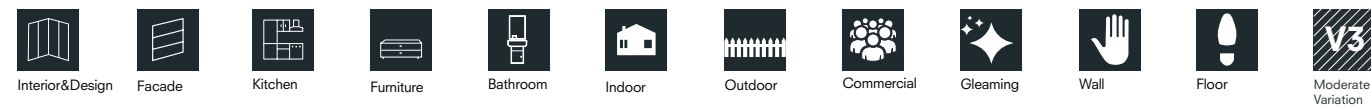

Marble Exclusive



SARRANCOLIN

	mm	Matte	Soft Matte	Polished	Satin
100x300 cm	3				
120x360 cm	3				
160x320 cm	6		•	•	
	12		•	•	
	20				
80x280 cm	6				



PATAGONIA

	mm	Matte	Soft Matte	Polished	Satin
100x300 cm	3				
120x360 cm	3				
160x320 cm	6			•	
	12		•	•	
	20				
80x280 cm	6				



QUARZITE J'ADORE

	mm	Matte	Soft Matte	Polished	Satin
100x300 cm	3				
120x360 cm	3				
160x320 cm	6	•		•	
	12	•		•	
	20				
80x280 cm	6				



OLIMPO*

	mm	Matte	Soft Matte	Polished	Satin
100x300 cm	3	•			
120x360 cm	3	•			
160x320 cm	6		•	•	
	12		•	•	
	20				
80x280 cm	6				



MARMO METALLO*

	mm	Matte	Soft Matte	Polished	Satin
100x300 cm	3	•			
120x360 cm	3	•			
160x320 cm	6		•		
	12		•		
	20				
80x280 cm	6				



ALASKA WHITE

	mm	Matte	Soft Matte	Polished	Satin
100x300 cm	3				
120x360 cm	3				
160x320 cm	6			•	
	12			•	
	20				
80x280 cm	6				

 *Glazing Surface: Regional shiny / sparkle effect on matte surface.

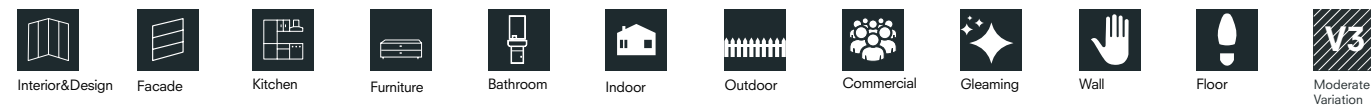

 *Glazing Surface: Regional shiny / sparkle effect on matte surface.

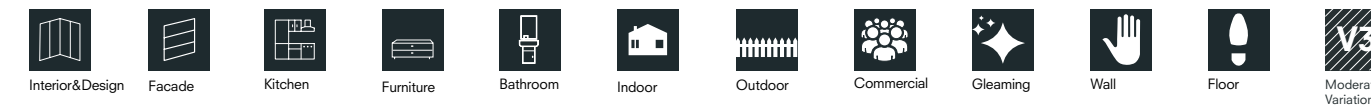

Marble Exclusive



MARINA

	mm	Matte	Soft Matte	Polished	Satin
100x300 cm	3				
120x360 cm	3				
6				•	
160x320 cm	12			•	
20					
80x280 cm	6				



VERSAILLES

	mm	Matte	Soft Matte	Polished	Satin
100x300 cm	3				
120x360 cm	3				
6					
160x320 cm	12		•		
20					
80x280 cm	6				



SKY

	mm	Matte	Soft Matte	Polished	Satin
100x300 cm	3				
120x360 cm	3				
6				•	
160x320 cm	12				
20					
80x280 cm	6				



SAHARA BROWN

	mm	Matte	Soft Matte	Polished	Satin
100x300 cm	3	•			
120x360 cm	3				
6			•		
160x320 cm	12		•		
20					
80x280 cm	6				



ALAMEDA

	mm	Matte	Soft Matte	Polished	Satin
100x300 cm	3	•			
120x360 cm	3		•		
6					
160x320 cm	12				
20					
80x280 cm	6				



ASTEROID

	mm	Matte	Soft Matte	Polished	Satin
100x300 cm	3	•			
120x360 cm	3		•		
6					
160x320 cm	12				
20					
80x280 cm	6				

✦ * Gleaming Surface: Regional shiny / sparkle effect on matte surface.

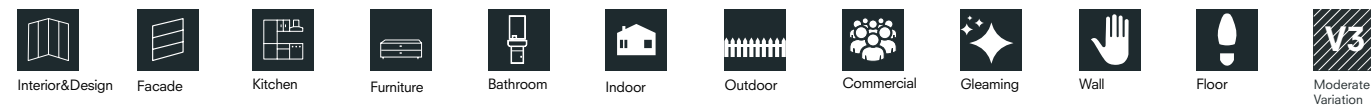

✦ * Gleaming Surface: Regional shiny / sparkle effect on matte surface.

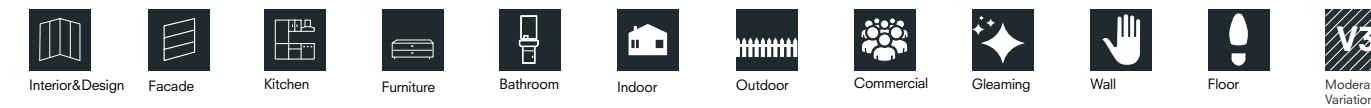

Marble Exclusive



MOCHA PERLA

	mm	Matte	Soft Matte	Polished	Satin
100x300 cm	3	•			
120x360 cm	3	•			
160x320 cm	6				
	12				
	20				
80x280 cm	6				

 *Gleaming Surface: Regional shiny / sparkle effect on matte surface.

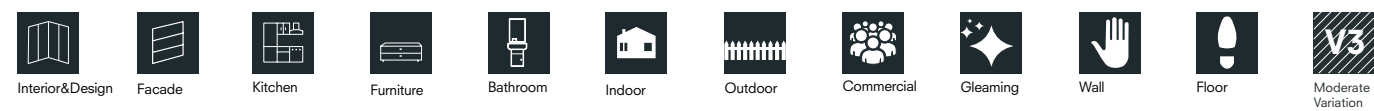

Marble Timeless



FIORI DI BOSCO

	mm	Matte	Soft Matte	Polished	Satin
100x300 cm	3				
120x360 cm	3				
160x320 cm	6	•		•	
	12	•		•	
	20				
80x280 cm	6				

 *Gleaming Surface: Regional shiny / sparkle effect on matte surface.



Marble Timeless



CRYSTALUS

	mm	Matte	Soft Matte	Polished	Satin
100x300 cm	3				
120x360 cm	3				
160x320 cm	6			•	
	12			•	
	20				
80x280 cm	6				



DENIS

	mm	Matte	Soft Matte	Polished	Satin
100x300 cm	3				
120x360 cm	3				
160x320 cm	6			•	
	12			•	
	20				
80x280 cm	6				



PULPIS

	mm	Matte	Soft Matte	Polished	Satin
100x300 cm	3	•			
120x360 cm	3	•			
160x320 cm	6				
	12				
	20				
80x280 cm	6				



SAVANA DARK

	mm	Matte	Soft Matte	Polished	Satin
100x300 cm	3				
120x360 cm	3				
160x320 cm	6				
	12				
	20				
80x280 cm	6				



TRANSLUCENT

	mm	Matte	Soft Matte	Polished	Satin
100x300 cm	3	•			
120x360 cm	3				
160x320 cm	6				
	12				
	20				
80x280 cm	6				

 *Glaming Surface: Regional shiny / sparkle effect on matte surface.

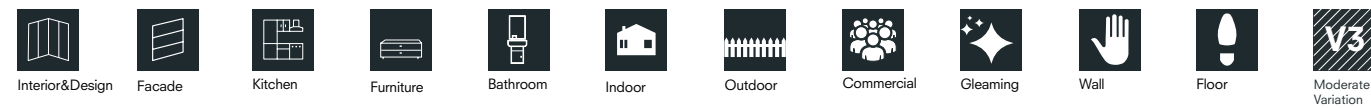

 *Glaming Surface: Regional shiny / sparkle effect on matte surface.



Cement



LUXURY CEMENT WHITE

	mm	Matte	Soft Matte	Polished	Satin
100x300 cm	3	•			
120x360 cm	3	•			
160x320 cm	6		•		
	12		•		
	20		•		
80x280 cm	6				



LUXURY CEMENT BEIGE

	mm	Matte	Soft Matte	Polished	Satin
100x300 cm	3	•			
120x360 cm	3	•			
160x320 cm	6		•		
	12		•		
	20		•		
80x280 cm	6				



LUXURY CEMENT GREY

	mm	Matte	Soft Matte	Polished	Satin
100x300 cm	3	•			
120x360 cm	3	•			
160x320 cm	6		•		
	12		•		
	20		•		
80x280 cm	6				



LUXURY CEMENT

	mm	Matte	Soft Matte	Polished	Satin
100x300 cm	3	•			
120x360 cm	3	•			
160x320 cm	6		•		
	12		•		
	20		•		
80x280 cm	6				



LUXURY CEMENT TAUPE

	mm	Matte	Soft Matte	Polished	Satin
100x300 cm	3	•			
120x360 cm	3	•			
160x320 cm	6		•		
	12		•		
	20		•		
80x280 cm	6				



LUXURY CEMENT MINK

	mm	Matte	Soft Matte	Polished	Satin
100x300 cm	3	•			
120x360 cm	3	•			
160x320 cm	6		•		
	12		•		
	20		•		
80x280 cm	6				

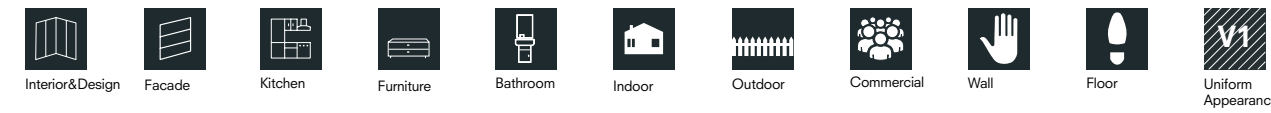
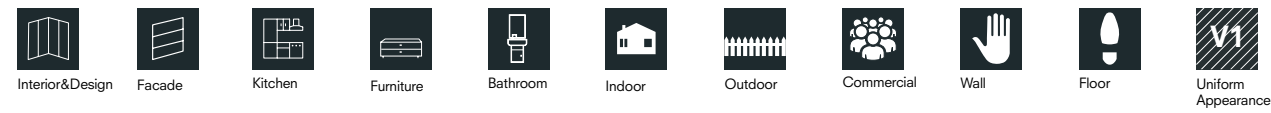

Cement



LUXURY CEMENT ANTHRACITE

	mm	Matte	Soft Matte	Polished	Satin
100x300 cm	3	•			
120x360 cm	3	•			
160x320 cm	6		•		
	12		•		
	20		•		
80x280 cm	6				



LUXURY CEMENT ANTHI

	mm	Matte	Soft Matte	Polished	Satin
100x300 cm	3	•			
120x360 cm	3	•			
160x320 cm	6		•		
	12		•		
	20		•		
80x280 cm	6				

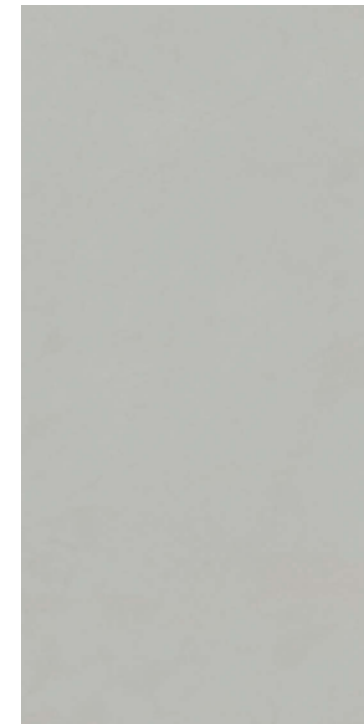

HUED OFF WHITE

	mm	Matte	Soft Matte	Polished	Satin
100x300 cm	3	•			
120x360 cm	3	•			
160x320 cm	6				
	12				
	20				
80x280 cm	6				



HUED GREY

	mm	Matte	Soft Matte	Polished	Satin
100x300 cm	3	•			
120x360 cm	3	•			
160x320 cm	6				
	12				
	20				
80x280 cm	6				

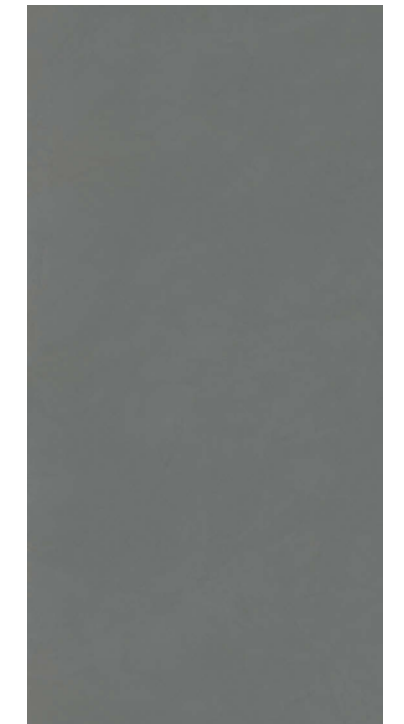

HUED DARK GREY

	mm	Matte	Soft Matte	Polished	Satin
100x300 cm	3	•			
120x360 cm	3	•			
160x320 cm	6				
	12				
	20				
80x280 cm	6				



 *Gleaming Surface: Regional shiny / sparkle effect on matte surface.

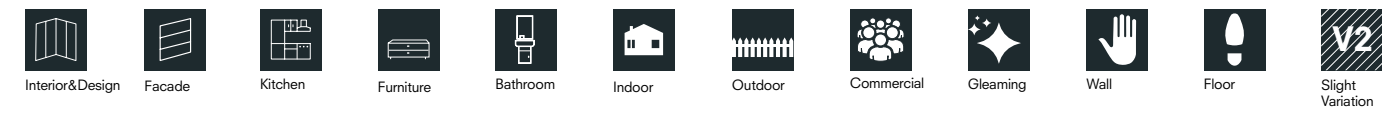

Cement

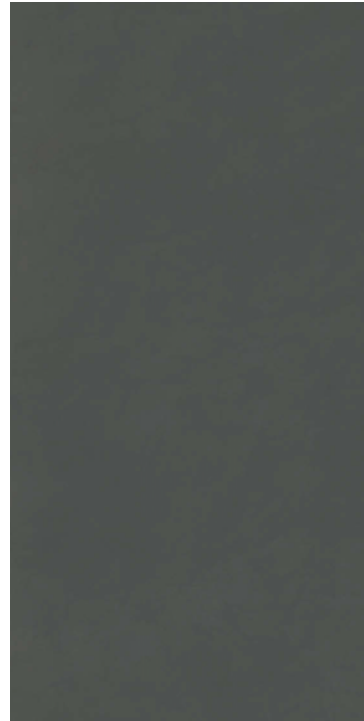

HUED ANTHRACITE

	mm	Matte	Soft Matte	Polished	Satin
100x300 cm	3	•			
120x360 cm	3	•			
160x320 cm	6				
	12				
	20				
80x280 cm	6				

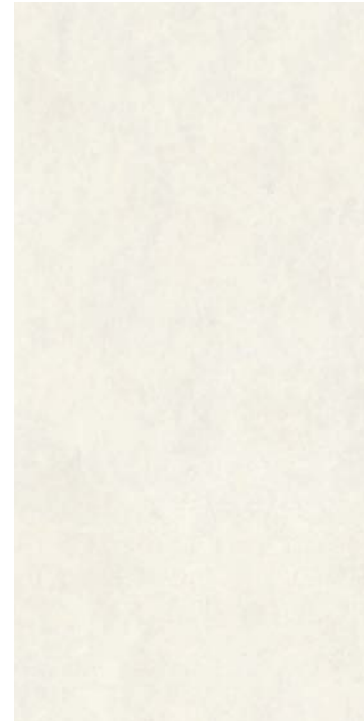

HIGHWAY BONE

	mm	Matte	Soft Matte	Polished	Satin
100x300 cm	3	•			
120x360 cm	3				
160x320 cm	6		•		
	12				
	20				
80x280 cm	6				



ARCHE WHITE

	mm	Matte	Soft Matte	Polished	Satin
100x300 cm	3	•			
120x360 cm	3				
160x320 cm	6				
	12				
	20				
80x280 cm	6				



ARCHE GREY

	mm	Matte	Soft Matte	Polished	Satin
100x300 cm	3	•			
120x360 cm	3				
160x320 cm	6				
	12				
	20				
80x280 cm	6				

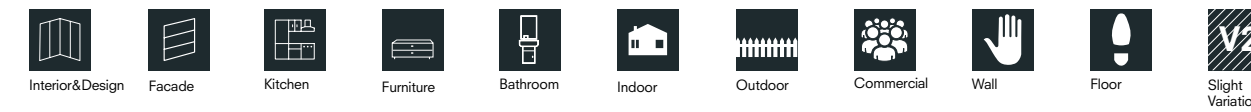
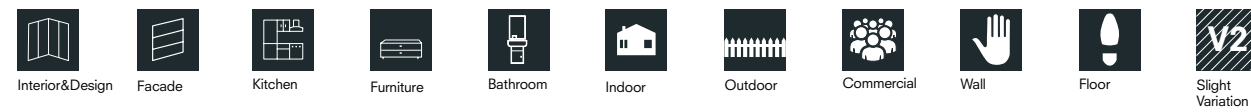

Stone



**NATURAL STONE
LECCESE LIGHT SAND**

	mm	Matte	Soft Matte	Polished	Satin
100x300 cm	3	•			
120x360 cm	3				
160x320 cm	6				
	12				
	20				
80x280 cm	6				

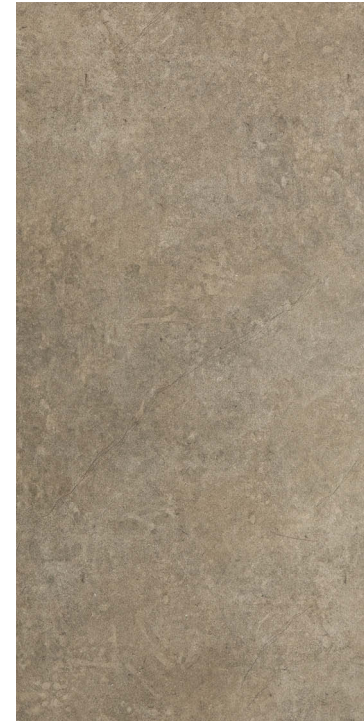

**NATURAL STONE
LECCESE DARK SAND**

	mm	Matte	Soft Matte	Polished	Satin
100x300 cm	3	•			
120x360 cm	3	•			
160x320 cm	6				
	12				
	20				
80x280 cm	6				

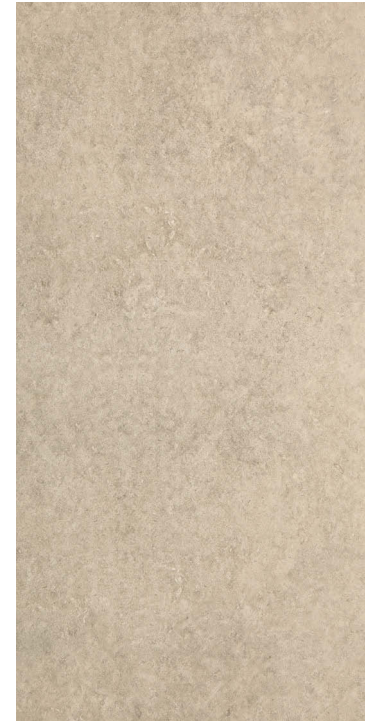

**NATURAL STONE
LECCESE GREY**

	mm	Matte	Soft Matte	Polished	Satin
100x300 cm	3	•			
120x360 cm	3				
160x320 cm	6				
	12				
	20				
80x280 cm	6				

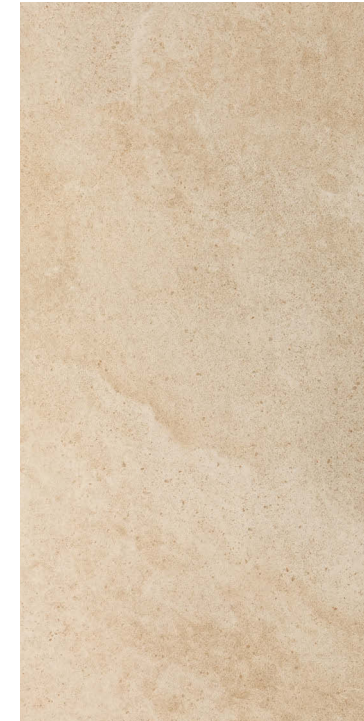

**NATURAL STONE
BRERA CREME**

	mm	Matte	Soft Matte	Polished	Satin
100x300 cm	3	•			
120x360 cm	3				
160x320 cm	6				
	12				
	20				
80x280 cm	6				



**NATURAL STONE
PIETRA BLUE**

	mm	Matte	Soft Matte	Polished	Satin	Rock Surface
100x300 cm	3	•				
120x360 cm	3	•				
160x320 cm	6					
	12		•			
	20					•
80x280 cm	6					



**NATURAL STONE
PIETRA GREY**

	mm	Matte	Soft Matte	Polished	Satin	Rock Surface
100x300 cm	3	•				
120x360 cm	3	•				
160x320 cm	6					
	12		•			
	20					•
80x280 cm	6					

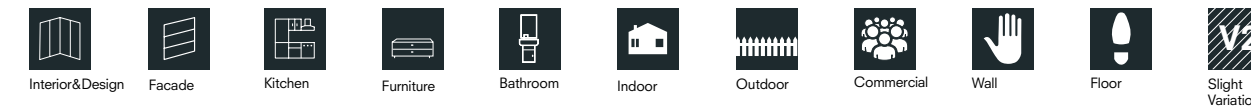
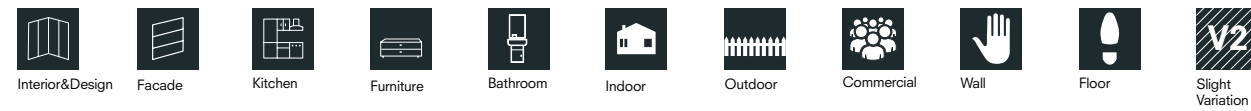

Stone

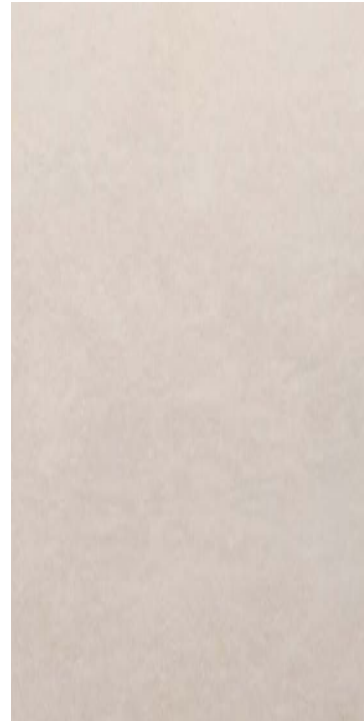

C-STONE WHITE

	mm	Matte	Soft Matte	Polished	Satin
100x300 cm	3	•			
120x360 cm	3	•			
6					
160x320 cm	12				
20					
80x280 cm	6				

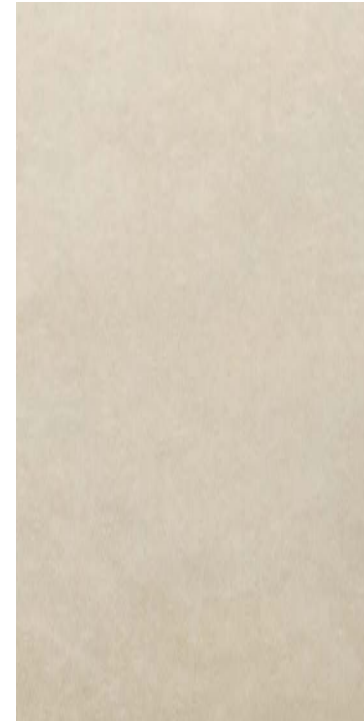

C-STONE BEIGE

	mm	Matte	Soft Matte	Polished	Satin
100x300 cm	3	•			
120x360 cm	3	•			
6					
160x320 cm	12				
20					
80x280 cm	6				



C-STONE GREY

	mm	Matte	Soft Matte	Polished	Satin
100x300 cm	3	•			
120x360 cm	3	•			
6					
160x320 cm	12				
20					
80x280 cm	6				



C-STONE DARK BROWN

	mm	Matte	Soft Matte	Polished	Satin
100x300 cm	3	•			
120x360 cm	3	•			
6					
160x320 cm	12				
20					
80x280 cm	6				



C-STONE ANTHRACITE

	mm	Matte	Soft Matte	Polished	Satin
100x300 cm	3	•			
120x360 cm	3	•			
6					
160x320 cm	12				
20					
80x280 cm	6				

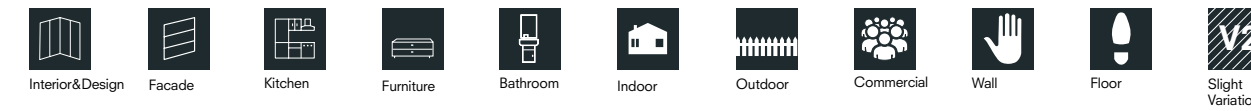
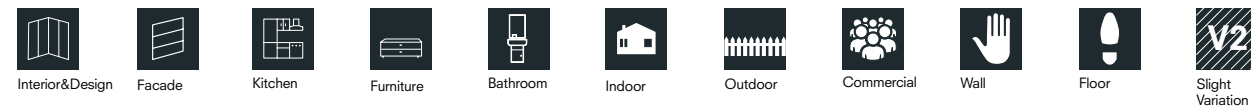

Stone

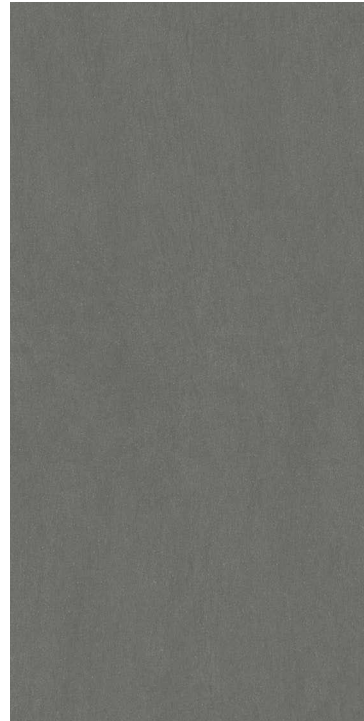

PIETRA BASALTINA



PIETRA CHATILLONN



OCEAN WHITE

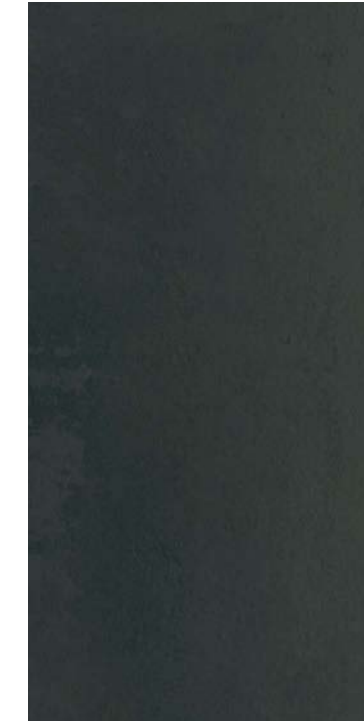

OCEAN BLACK

	mm	Matte	Soft Matte	Polished	Satin	Rock Surface
100x300 cm	3	•				
120x360 cm	3					
	6					
160x320 cm	12		•			
	20					•
80x280 cm	6					

	mm	Matte	Soft Matte	Polished	Satin
100x300 cm	3	•			
120x360 cm	3				
	6				
160x320 cm	12				
	20				
80x280 cm	6				

	mm	Matte	Soft Matte	Polished	Satin
100x300 cm	3	•			
120x360 cm	3				
	6				
160x320 cm	12		•		
	20				
80x280 cm	6				

	mm	Matte	Soft Matte	Polished	Satin
100x300 cm	3	•			
120x360 cm	3				
	6				
160x320 cm	12		•		
	20				
80x280 cm	6				

 *Gleaming Surface: Regional shiny / sparkle effect on matte surface.

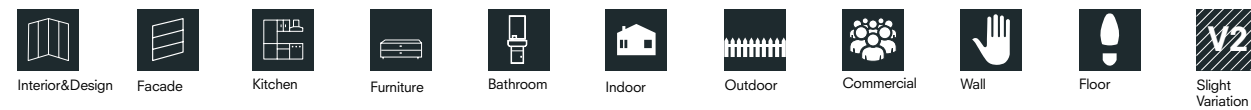

Stone



**STONELAND
PIETRA DI GREY**

	mm	Matte	Soft Matte	Polished	Satin
100x300 cm	3	•			
120x360 cm	3	•			
160x320 cm	6		•		
	12		•		
	20		•		
80x280 cm	6				



**STONELAND
PIETRA DI BONE**

	mm	Matte	Soft Matte	Polished	Satin
100x300 cm	3	•			
120x360 cm	3	•			
160x320 cm	6		•		
	12		•		
	20		•		
162x323 cm	6				
	12				
	20				



TERRAZZO

	mm	Matte	Soft Matte	Polished	Satin
100x300 cm	3				
120x360 cm	3				
160x320 cm	6				
	12				
	20				
80x280 cm	6				



UPTOWN LIGHT

	mm	Matte	Soft Matte	Polished	Satin
100x300 cm	3	•			
120x360 cm	3	•			
160x320 cm	6				
	12				
	20				
80x280 cm	6				



UPTOWN DARK

	mm	Matte	Soft Matte	Polished	Satin
100x300 cm	3	•			
120x360 cm	3	•			
160x320 cm	6				
	12				
	20				
80x280 cm	6				

 *Gleaming Surface: Regional shiny / sparkle effect on matte surface.

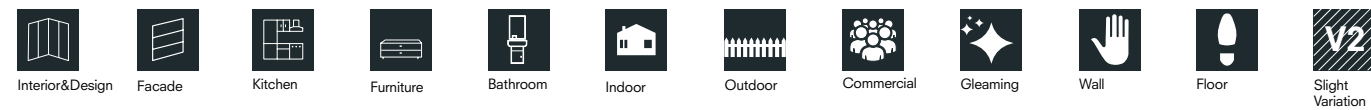

Stone



STONE GALLERY QUARTZ ASH

	mm	Matte	Soft Matte	Polished	Satin
100x300 cm	3	•			
120x360 cm	3				
160x320 cm	6				
	12				
80x280 cm	12				
	20				
80x280 cm	6				



OMNITECH MONOLITH GREY

	mm	Matte	Soft Matte	Polished	Satin
100x300 cm	3	•			
120x360 cm	3	•			
160x320 cm	6		•		
	12				
80x280 cm	12				
	20				
80x280 cm	6				



OMNITECH PIEMONTE GREY

	mm	Matte	Soft Matte	Polished	Satin
100x300 cm	3	•			
120x360 cm	3	•			
160x320 cm	6				
	12		•		
80x280 cm	12				
	20				
80x280 cm	6				



Interior&Design



Facade



Kitchen



Furniture



Bathroom



Indoor



Outdoor



Commercial



Wall



Floor



Slight Variation

Stone



**EARTH COLLECTION
TRAVERTINE SILVER**

	mm	Matte	Soft Matte	Polished	Satin
100x300 cm	3	•			
120x360 cm	3	•			
160x320 cm	6		•		
	12		•		
	20		•		
80x280 cm	6				



**EARTH COLLECTION
RAPOLANO IVORY**

	mm	Matte	Soft Matte	Polished	Satin
100x300 cm	3	•			
120x360 cm	3	•			
160x320 cm	6		•		
	12		•		
	20		•		
80x280 cm	6				



**EARTH COLLECTION
TRAVERTINE IVORY**

	mm	Matte	Soft Matte	Polished	Satin
100x300 cm	3	•			
120x360 cm	3	•			
160x320 cm	6		•		
	12		•		
	20		•		
80x280 cm	6				



CALCARIO COLLECTION

	mm	Matte	Soft Matte	Polished	Satin	Rock Surface
100x300 cm	3					
120x360 cm	3					
160x320 cm	6		•			
	12		•			
	20		•			•
80x280 cm	6					



CALCARIO COLLECTION LINE

	mm	Matte	Soft Matte	Polished	Satin	Rock Surface
100x300 cm	3					
120x360 cm	3					
160x320 cm	6		•			
	12		•			
	20		•			•
80x280 cm	6					

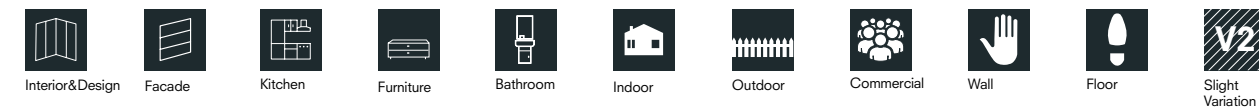
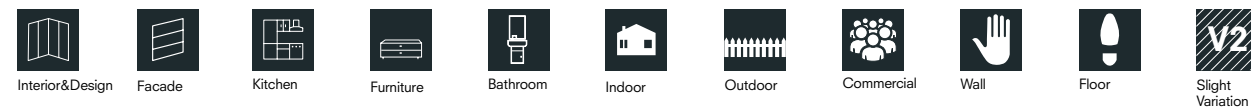

Metallic



METALLIC ANTHRACITE

	mm	Matte	Soft Matte	Polished	Satin
100x300 cm	3	•			
120x360 cm	3				
6					
160x320 cm	12		•		
20					
80x280 cm	6				



METALLIC CORAL

	mm	Matte	Soft Matte	Polished	Satin
100x300 cm	3	•			
120x360 cm	3				
6					
160x320 cm	12		•		
20					
80x280 cm	6				



OXIDO FLAME

	mm	Matte	Soft Matte	Polished	Satin
100x300 cm	3	•			
120x360 cm	3	•			
6					
160x320 cm	12				
20					
80x280 cm	6				



OXIDO ICE

	mm	Matte	Soft Matte	Polished	Satin
100x300 cm	3	•			
120x360 cm	3	•			
6					
160x320 cm	12				
20					
80x280 cm	6				



OXIDO OIL

	mm	Matte	Soft Matte	Polished	Satin
100x300 cm	3	•			
120x360 cm	3	•			
6					
160x320 cm	12				
20					
80x280 cm	6				



OXIDO MOSS

	mm	Matte	Soft Matte	Polished	Satin
100x300 cm	3	•			
120x360 cm	3	•			
6					
160x320 cm	12				
20					
80x280 cm	6				

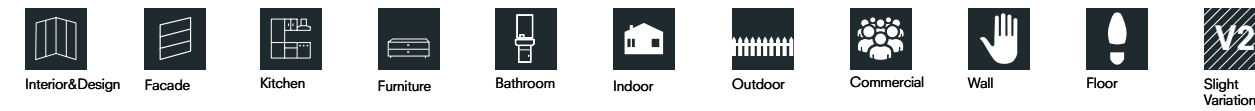
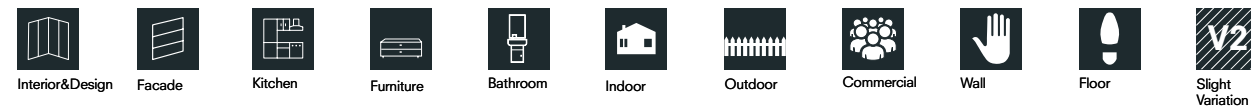

Woodline



HOLLYWOOD BEIGE

	mm	Matte	Soft Matte	Polished	Satin
100x300 cm	3	•			
120x360 cm	3	•			
	6				
160x320 cm	12				
	20				
80x280 cm	6				



HOLLYWOOD BROWN

	mm	Matte	Soft Matte	Polished	Satin
100x300 cm	3		•		
120x360 cm	3		•		
	6				
160x320 cm	12				
	20				
80x280 cm	6				



WOODLINE WALNUT

	mm	Matte	Soft Matte	Polished	Satin
100x300 cm	3	•			
120x360 cm	3				
	6				
160x320 cm	12				
	20				
80x280 cm	6				



WOODLINE CHERRY

	mm	Matte	Soft Matte	Polished	Satin
100x300 cm	3	•			
120x360 cm	3				
	6				
160x320 cm	12				
	20				
80x280 cm	6				



WOODLINE OAK

	mm	Matte	Soft Matte	Polished	Satin
100x300 cm	3	•			
120x360 cm	3				
	6				
160x320 cm	12				
	20				
80x280 cm	6				

✦ *Glaming Surface: Regional shiny / sparkle effect on matte surface.

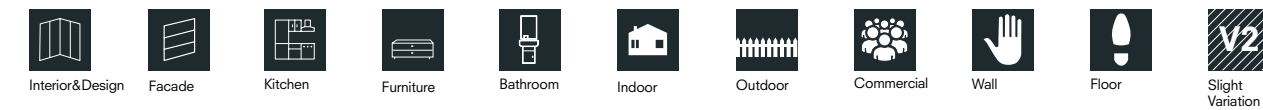
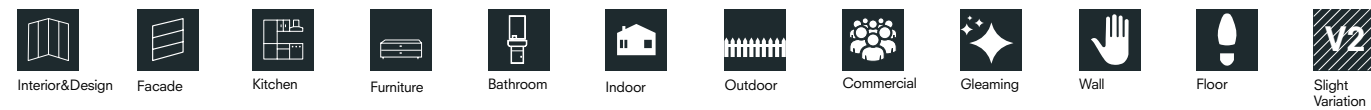

Woodline



PLANK BG 104

	mm	Matte	Soft Matte	Polished	Satin
100x300 cm	3	•			
120x360 cm	3				
160x320 cm	6				
	12				
	20				
80x280 cm	6				



PLANK BG 110

	mm	Matte	Soft Matte	Polished	Satin
100x300 cm	3	•			
120x360 cm	3				
160x320 cm	6				
	12				
	20				
80x280 cm	6				



PLANK BG 111

	mm	Matte	Soft Matte	Polished	Satin
100x300 cm	3	•			
120x360 cm	3				
160x320 cm	6				
	12				
	20				
80x280 cm	6				



PLANK BG 114

	mm	Matte	Soft Matte	Polished	Satin
100x300 cm	3	•			
120x360 cm	3				
160x320 cm	6				
	12				
	20				
80x280 cm	6				



SHELL WOOD DARK

	mm	Matte	Soft Matte	Polished	Satin
100x300 cm	3	•			
120x360 cm	3	•			
160x320 cm	6				
	12				
	20				
80x280 cm	6				

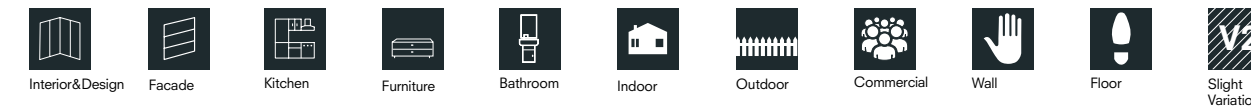
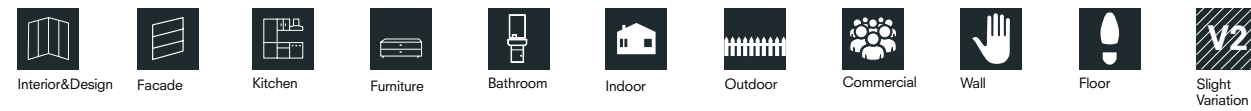

Design Collection



COASTAL A



COASTAL B



COASTAL C

	Matte	Soft Matte	Polished	Satin
100x280 cm	•			



LUEVEN A



LUEVEN B

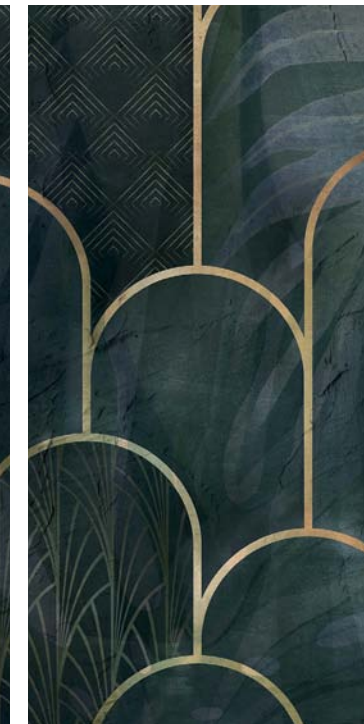

LUEVEN C

	Matte	Soft Matte	Polished	Satin
100x280 cm	•			



Interior&Design



Wall



Interior&Design



Wall

Design Collection



PLAIN SPRING A



PLAIN SPRING B



PLAIN SPRING C

	Matte	Soft Matte	Polished	Satin
100x280 cm	•			



RED BLOSSOMS A



RED BLOSSOMS B



RED BLOSSOMS C

	Matte	Soft Matte	Polished	Satin
100x280 cm	•			



Interior&Design



Wall



Interior&Design



Wall

Design Collection



COLOR DIVE A

COLOR DIVE B

	Matte	Soft Matte	Polished	Satin
100x280 cm	•			



Interior&Design



Wall





INDEX



A COMPLETE
PRODUCT
SYSTEM



PRODUCT
FINDER



LOOK



COMPANY



KALESINTERFLEX



T-ONE



TECHNICAL
SPECIFICATIONS



Spaces

- > Bathrooms
- > Kitchens
- > Interior
- > Exterior



INDEX



A COMPLETE
PRODUCT
SYSTEM



PRODUCT
FINDER



LOOK



COMPANY



KALESINTERFLEX



T-ONE



TECHNICAL
SPECIFICATIONS

Spaces / Bathrooms / Kalesinterflex

THE EXCITEMENT OF
INNOVATION,
EXPERIENCED
IN BATHROOMS...

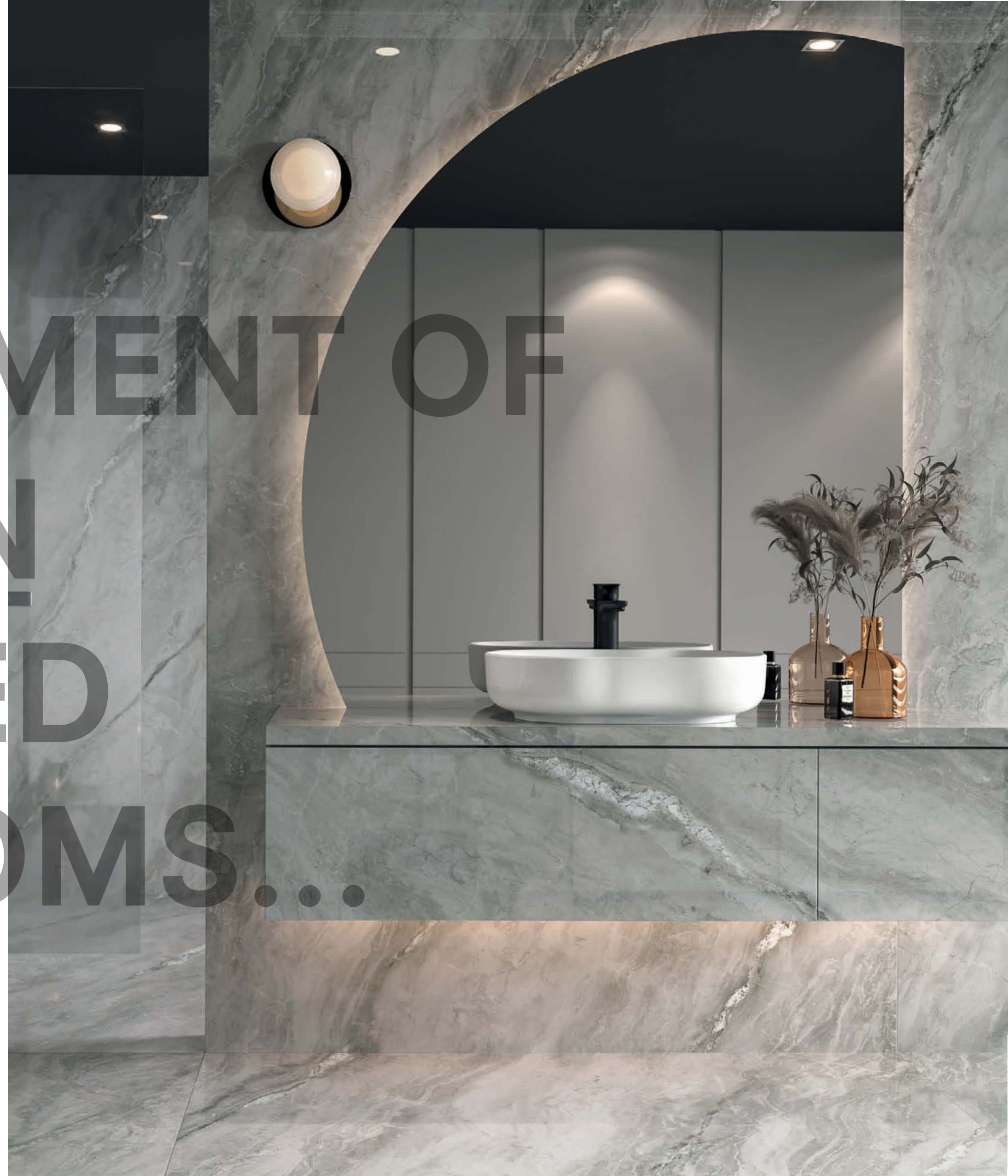



INDEX



A COMPLETE
PRODUCT
SYSTEM



PRODUCT
FINDER



LOOK



COMPANY



KALESINTERFLEX



T-ONE



TECHNICAL
SPECIFICATIONS

Spaces / Bathrooms / Kalesinterflex

We combine design with functionality for a completely different bathroom experience, and bring Kalesinterflex porcelain slab, which has been the inspiration of architecture for years.

With its advantage of offering limitless and boundless options on different surfaces, Kalesinterflex provides a comfortable bathroom experience with its water-resistant, stain-resistant, and scratch-resistant features, making it ideal for bathrooms where water and moisture are abundant.

AN INNOVATION TOUCH...

YOUR BATHROOM IS NOW MUCH **MORE ELEGANT.**





INDEX



A COMPLETE
PRODUCT
SYSTEM



PRODUCT
FINDER



LOOK



COMPANY



KALESINTERFLEX



T-ONE



TECHNICAL
SPECIFICATIONS

Spaces / Bathrooms / Kalesinterflex



**KALESINTERFLEX PRIVILEGES
ARE IN YOUR BATHROOM NOW!**

AESTHETIC

We turn the time you spend in your bathroom into unique experiences with the products taking shape according to your pleasure. We design timeless bathrooms with the aesthetic textures taking inspiration from the earth.

DURABLE

We combine hygiene, durability, functionality and elegance in one place with stain-proof and scratch-proof designs. With Kalesinterflex we carry the comfort in the bathroom experience to the top.

HYGIENIC

Kalesinterflex porcelain slab, which is resistant to water, steam, and moisture thanks to its superior surface performance, brings a modern and functional interpretation to bathroom furniture.

While offering a healthy bathroom experience with its easy-to-clean and hygienic surface, it provides long-lasting use with its scratch-proof structure.



INDEX



A COMPLETE
PRODUCT
SYSTEM



PRODUCT
FINDER



LOOK



COMPANY



KALESINTERFLEX



T-ONE



TECHNICAL
SPECIFICATIONS



YOUR BATHROOM IS NOW
MUCH MORE ELEGANT



INDEX



A COMPLETE
PRODUCT
SYSTEM



PRODUCT
FINDER



LOOK



COMPANY



KALESINTERFLEX



T-ONE



TECHNICAL
SPECIFICATIONS

Spaces / Kitchens / Kalesinterflex

Life is changing, habits are changing, designs are changing, but mankind's keenness to seek for the new never does. The everyday materials in modern life are gaining new meanings. Because now everyone prefers products that they reflect their own style on, choose according to their tastes and can fine tune every detail.

More comfortable and functional living spaces are designed with materials that offer different features in one place. We call it the beginning of the future..

**ENHANCE
YOUR KITCHEN
EXPERIENCE
WITH STYLE AND
DURABILITY.**





INDEX



A COMPLETE
PRODUCT
SYSTEM



PRODUCT
FINDER



LOOK



COMPANY



KALESINTERFLEX



T-ONE



TECHNICAL
SPECIFICATIONS



UNIQUE COLORS
APPEALING TO
EVERY TASTE!



INDEX



A COMPLETE
PRODUCT
SYSTEM



PRODUCT
FINDER



LOOK



COMPANY



KALESINTERFLEX



T-ONE



TECHNICAL
SPECIFICATIONS

Spaces / Interior / Kalesinterflex

Kalesinterflex, which combines elegance and functionality in every place where there is life, such as home, office, hotel, lobby, restaurant, and shopping mall, adds character to interiors with its sizes, rich color alternatives, original patterns, and durable surface, which adapt to every space.

Kalesinterflex guarantees the perfect mix of style and technical performance with its lightweight composition, firm structure, hygienic, aesthetic, durable, and stain-resistant feature. It can be used

**from tables to side boards,
coffee tables, and outdoor
furniture with its durable
structure.**





INDEX



A COMPLETE
PRODUCT
SYSTEM



PRODUCT
FINDER



LOOK



COMPANY



KALESINTERFLEX



T-ONE



TECHNICAL
SPECIFICATIONS

Spaces / Interior / Kalesinterflex

You can freely design your living spaces with Kalesinterflex furniture, reflecting your style through colors and details. With alternative choices that match your taste, you can achieve perfect harmony with other pieces of furniture. Kalesinterflex furniture goes beyond your expectations, as it is scratch-resistant, stain-resistant, and requires minimal maintenance. It is highly durable against heat and cold, easy to clean, exhibits high resistance to UV rays, and stands out by being effortlessly cleaned compared to ordinary furniture.





INDEX



A COMPLETE
PRODUCT
SYSTEM



PRODUCT
FINDER



LOOK



COMPANY



KALESINTERFLEX



T-ONE



TECHNICAL
SPECIFICATIONS





INDEX



A COMPLETE
PRODUCT
SYSTEM



PRODUCT
FINDER



LOOK



COMPANY



KALESINTERFLEX



T-ONE



TECHNICAL
SPECIFICATIONS

Spaces / Exterior / Kalesinterflex

Preferred as the facade cladding of prestigious buildings, Kalesinterflex offers long-lasting use thanks to its surface that is

super resistant to

sunlight and different weather conditions.



An-San Marine



INDEX



A COMPLETE
PRODUCT
SYSTEM



PRODUCT
FINDER



LOOK



COMPANY



KALESINTERFLEX



T-ONE



TECHNICAL
SPECIFICATIONS

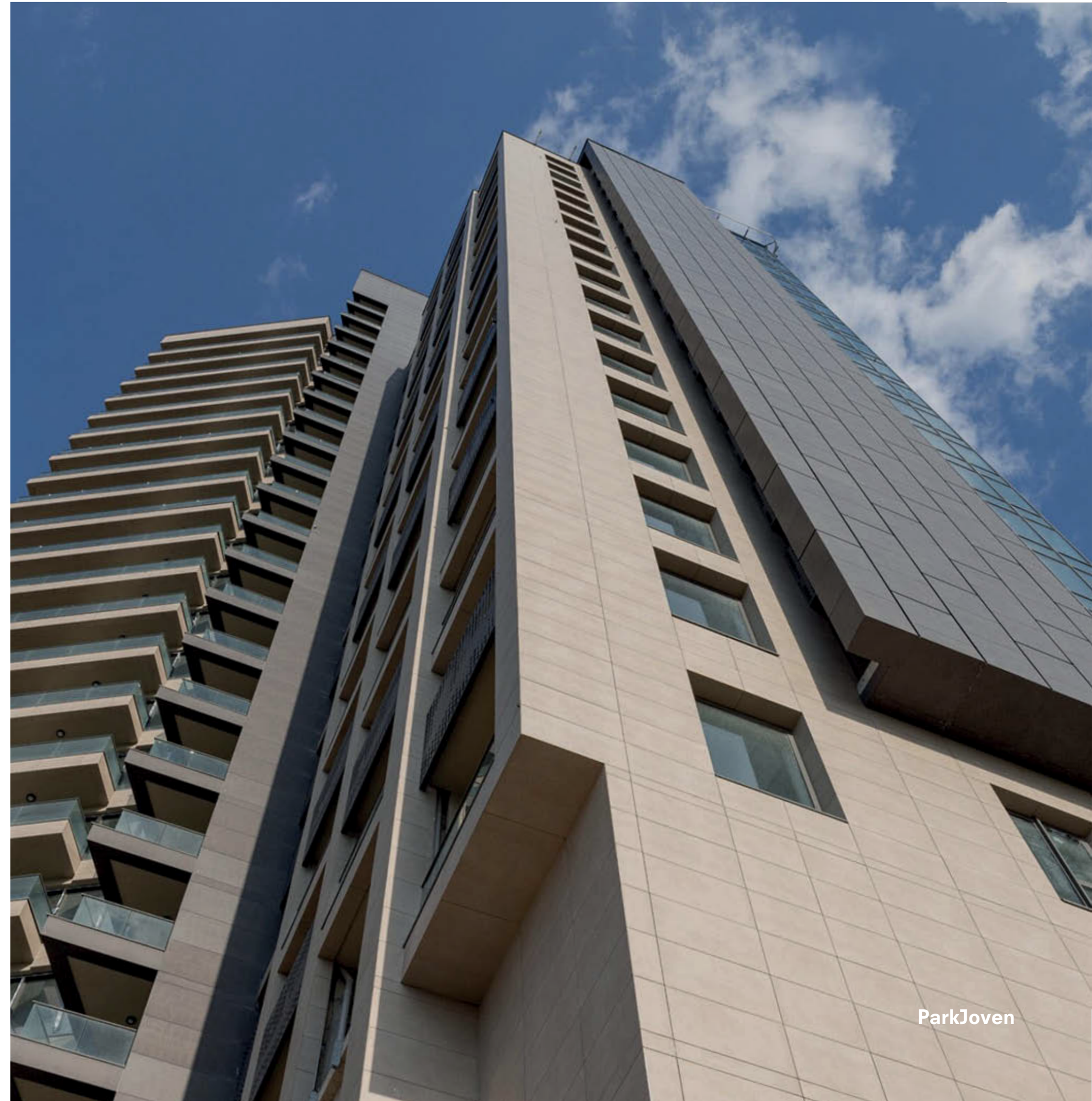
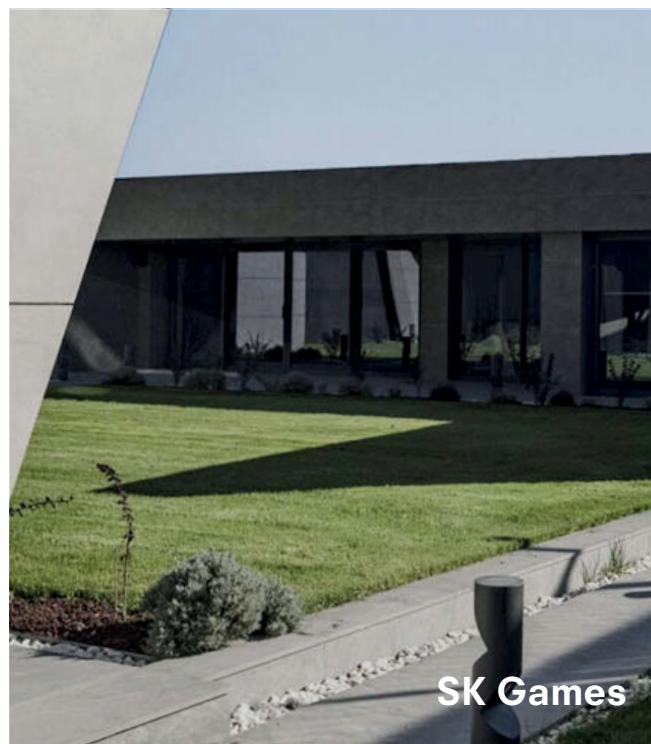



INDEX



A COMPLETE
PRODUCT
SYSTEM



PRODUCT
FINDER



LOOK



COMPANY



KALESINTERFLEX



T-ONE



TECHNICAL
SPECIFICATIONS

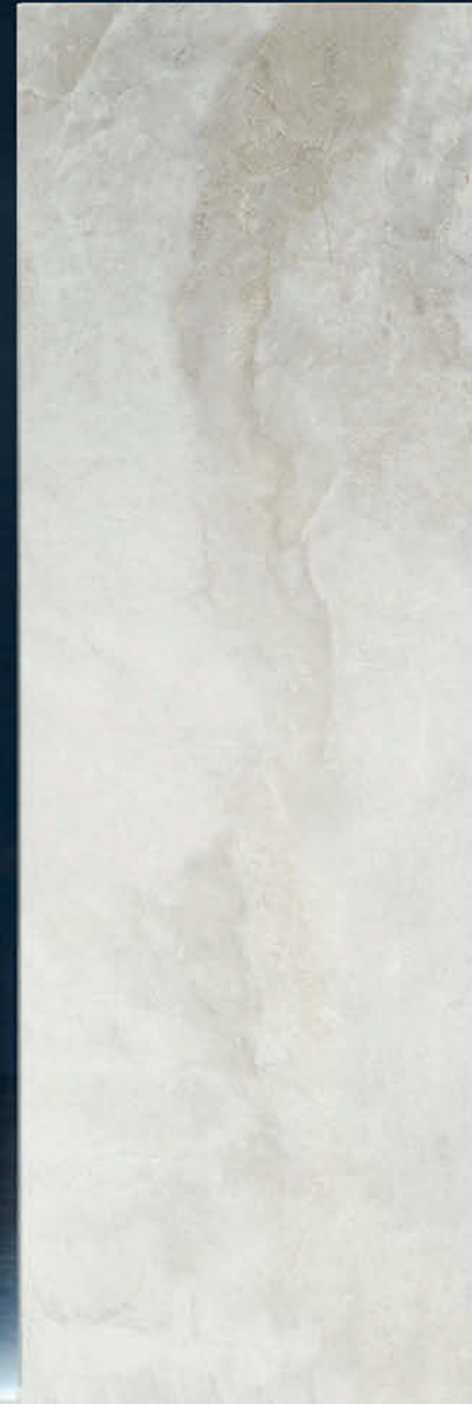

Technology

- > Decotech
- > Bodytech
- > Flowtech
- > Openbook
- > Glowtech
- > V-Intech
- > Formtech

Technology / Kalesinterflex



— BODYTECH —

The technology of Consistency

BODYTECH technology, which refers to the use of salt-pepper-masse in traditional porcelain production, is constituted from finely ground masse mixtures containing homogeneous stone textures and different color shades on the surface of the products. Thanks to the special method that carries the visual effect on the surface of the product to the product structure, each edge and each cut point of the product offers a harmonious and holistic appearance with the surface.



— FLOWTECH —

The technology of Eternity

FLOWTECH, used as a pattern tracking technology, ensures the progression of the pattern between the panels of marble-look products in particular. It creates a more impressive ambiance in wall applications in spaces.

Some marble products were designed using this method. However, during the production phase, the products are produced in a combination. Practitioners should make the right choice during the covering to capture this flow. Thus, the aesthetic and design potential of the space is maximized.

— DECOTECH —

The technology of Art

DECOTECH technology, which stands out due to the application of special materials to the surfaces and their separation from flatly printed products, and matte or glossy materials bearing the name of granilla create a striking relief effect on the products.

Reliefs, which can be applied synchronously or independently according to different design needs and wishes, are often preferred in decorative and positive spaces.

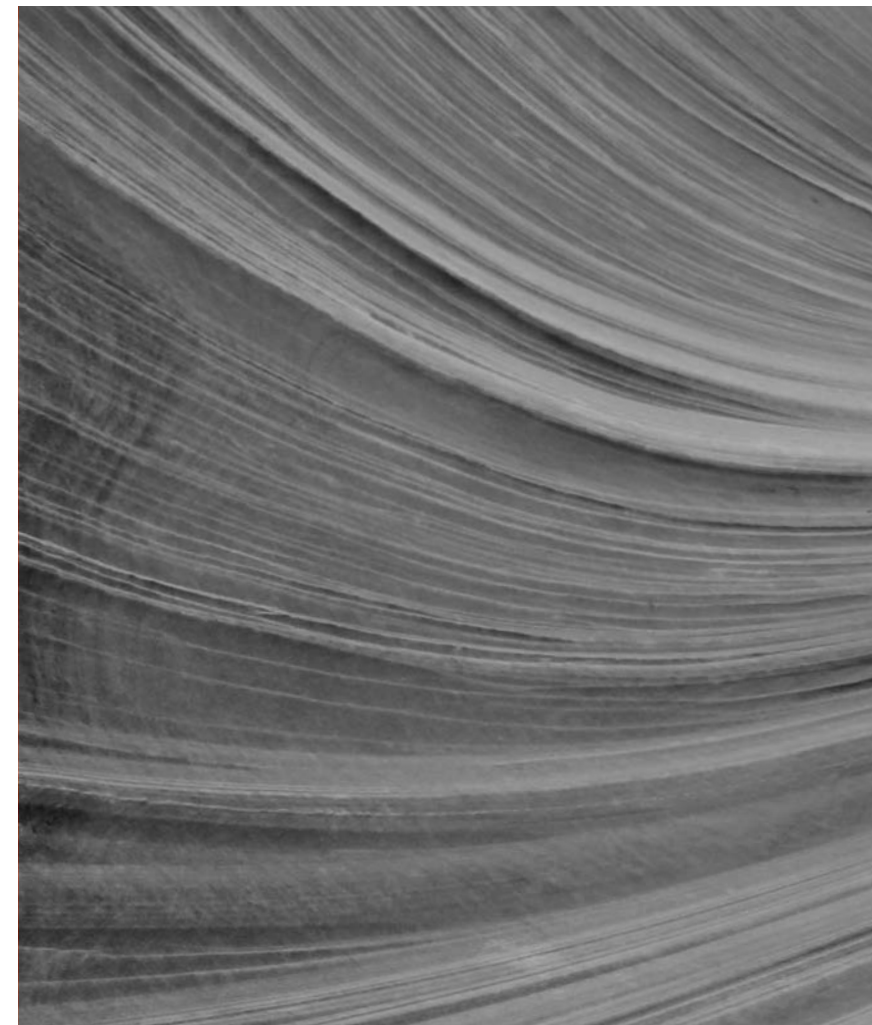

Technology / Kalesinterflex

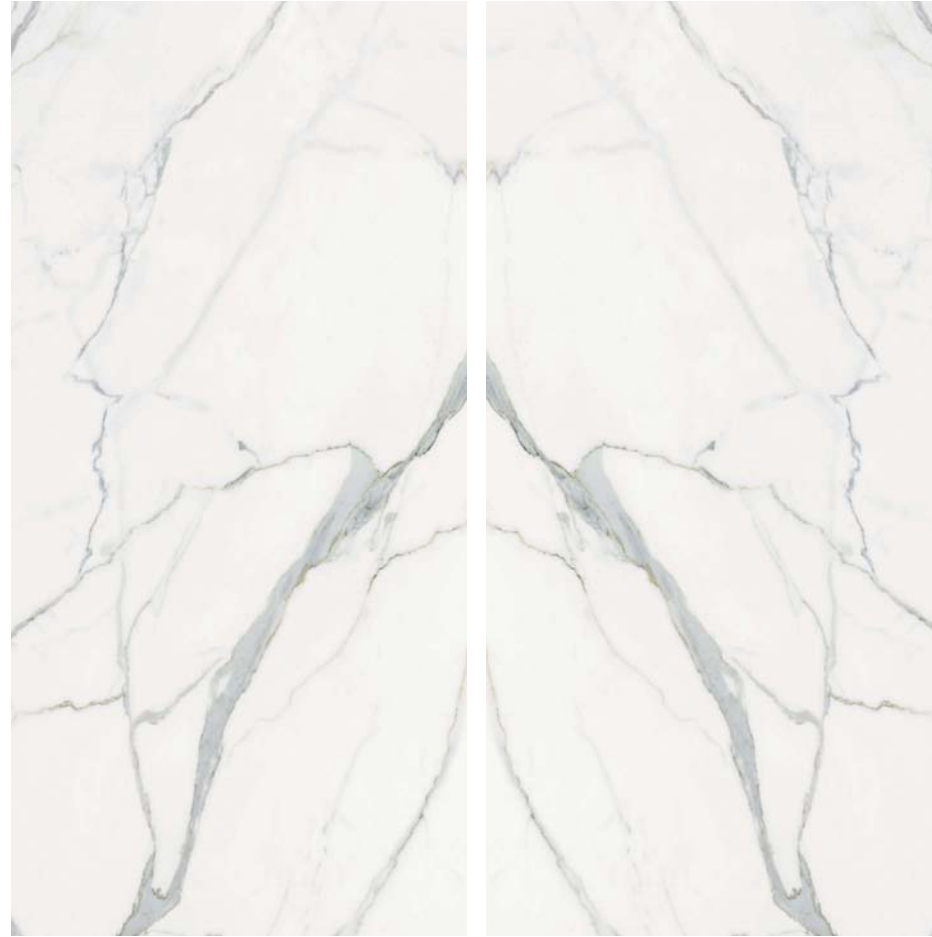

— OPENBOOK —

The technology of Symmetry

OPENBOOK, used as a Correspondent Pattern Technology, enables one module to come face to face with the other module and create a unique pattern, especially in marble-look products. This special design distinguishes both modules as A and B with different codes while allowing small pattern shifts of 1-2 cm between them.

Thanks to this method, aesthetic and visual diversity is achieved in spaces, and the integrity of the design is preserved.

— GLOWTECH —

The technology of Sparkle

GLOWTECH, used as Metallic Glow Technology, refers to the effect caused by the glare of micro-metallic pieces on the surface of glossy products.

This special effect gives the products a more exclusive and eye-catching glow by distinguishing them from standard glossy ones. While it is described as the reflection of the natural mineral glow in some marbles on the ceramic technology, an aesthetic and elegant shine is obtained in the spaces.

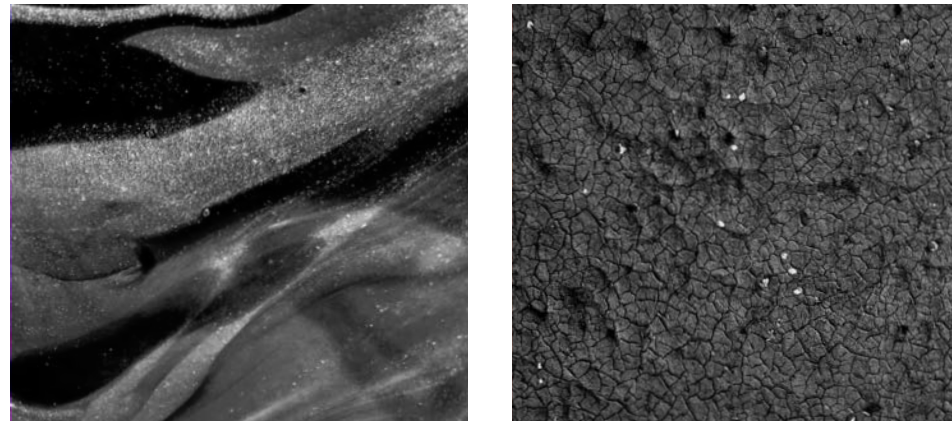

— FORMTECH —

The technology of Sensation

Porcelain slabs mimicking the appearance of natural stone carry aesthetic elegance to living spaces. FORMTECH shapes porcelain slabs with inspiration from nature.

Bringing surfaces an embossed and ragged feel, FORMTECH technology adds depth to spaces. Special surfaces adapted to different patterns, textures and colors offer visual richness to living spaces. It creates a more attractive and unique atmosphere in every space.



— V-INTECH —

The technology of Nature

Through V-INTECH technology carrying the homogeneous stone texture to the marble, different colored masse mixtures are integrated into the product structure in accordance with the product pattern.

While marble veins continue within the product as well with this technology, in which marble patterns are often used, details of the marble are engraved on the product surface with digital printing, and as a result, a very natural appearance is obtained.

While the progression of the vessels is ensured at the edges and sections of the tile, Bodytech technology is used for a realistic appearance in cases where the tile section remains open.

INDEX

A COMPLETE PRODUCT SYSTEM

PRODUCT FINDER

LOOK

COMPANY

KALESINTERFLEX

T-ONE

TECHNICAL SPECIFICATIONS



T-ONE

Superior Porcelain Countertop



WATCH THE VIDEO

- INDEX
- A COMPLETE PRODUCT SYSTEM
- PRODUCT FINDER
- LOOK
- COMPANY
- KALESINTERFLEX
- T-ONE
- TECHNICAL SPECIFICATIONS



T-One

- > T-One Porcelain Countertop
- > Thicknesses - Sizes
- > Features
- > T-One In The Spotlight: Chefs Share Their Thoughts
- > Products



INDEX



A COMPLETE
PRODUCT
SYSTEM



PRODUCT
FINDER



LOOK



COMPANY



KALESINTERFLEX



T-ONE



TECHNICAL
SPECIFICATIONS

T-One Porcelain Countertop / T-One

TRANSFORM YOUR KITCHEN EXPERIENCE.

Turkey's first and only porcelain countertop, T-One transforms your kitchen experience with its stunning beauty, its future-forward technology, its unrivaled performance and its sheer ability to make life as joyful as it was meant to be. It's easy to clean and wildly resistant to even the most extreme heat and cold. As resistant as it is to stains, scratches and abrasion. It's fireproof and environmentally friendly. Cooking never looked this good and performed this perfectly.

KITCHENS GET CLASS WITH PORCELAIN COUNTERTOP!

Securing its place in modern kitchens, T-One Porcelain Countertop is designed to further your joy in kitchen with its durable structure, hygienic surface and aesthetic appearance. Produced with Kalesinterflex porcelain slabs with excellent performance levels that break the mold in the architecture, T-One Porcelain Countertop, is equipped with features that can meet all your expectations.

STRENGTH ABOVE ALL!

T-One Porcelain Countertop, always protects itself against different usage and environmental conditions and thus will accompany you for years with its durability in the kitchens where we spend a lot of time in our home. You can chop any food you want on it without scratching, thanks to its unique surface. You can put any cooking equipment you've just taken out of the oven or of the stove on your countertop, and easily clean it with the household cleaning products you want.

A "CLEAN" SHEET IN THE KITCHENS!

The hygiene of our kitchens is of vital importance with regard to nutritional health. T-One Porcelain Countertop, due to its non-porous structure, offers a comfortable and hygienic kitchen experience. It is also quick and easy to clean with household cleaning products.

Transform your kitchen experience.

Thicknesses - Sizes / T-One

T-One Porcelain Countertop consists of porcelain slabs that have **160x320cm** and **162x323cm** sizes and **12mm - 20mm** thickness.

20mm



12mm



INDEX

A COMPLETE
PRODUCT
SYSTEM

PRODUCT
FINDER

LOOK

COMPANY

KALESINTERFLEX

T-ONE

TECHNICAL
SPECIFICATIONS

Features / T-One

THE INNOVATIVE FACE OF LIVING KITCHENS



HYGIENIC

Due to their non-porous structure, T-One countertops resist harmful bacteria, so you never have to worry about safely cooking your food.



RESISTANCE TO SCRATCHES

T-One's super hard porcelain lets you cut any food without worrying about scratching or abrasion.

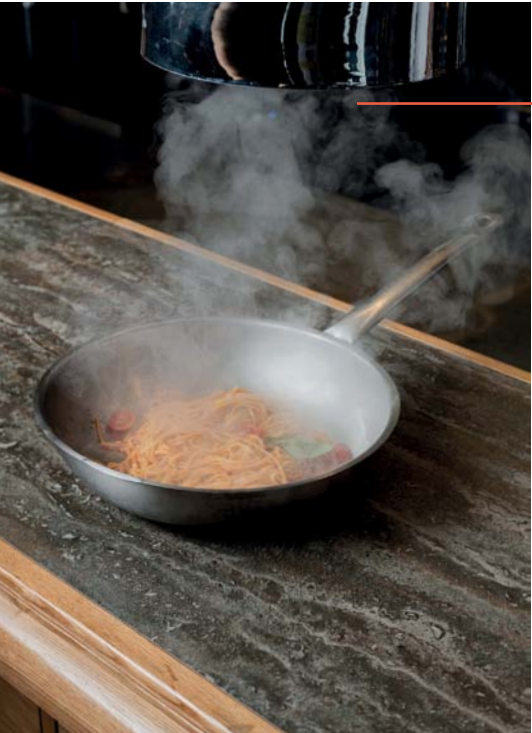

FIREPROOF

T-One is fireproof so you can safely move your pots and pans from the oven or range to your counter.



EASY TO CLEAN

It's quick and easy to clean your T-One countertop with household cleaning products.

DURABLE

No countertop lasts longer thanks to T-One's high performance, high durability structure.

RESISTANT TO UV RAYS

T-One is UV resistant and nonfading when exposed to sunlight.



AESTHETIC

A wide variety of colors and patterns mean your T-One countertop fits right in with the rest of your kitchen.



HIGH STAIN RESISTANCE

Permanent stains like tea, coffee and lemon are a thing of the past thanks to T-One's non-porous structure.

 WATCH THE VIDEO

INDEX

A COMPLETE
PRODUCT
SYSTEM

PRODUCT
FINDER

LOOK

COMPANY

KALESINTERFLEX

T-ONE

TECHNICAL
SPECIFICATIONS

T-One In The Spotlight: Chefs Share Their Thoughts / T-One



CHEF ARDA TÜRKMEN

"The T-One Porcelain Countertop is my choice at home, in the studio and the kitchen. It is scratch resistant, stain-proof and extremely durable against heat, and rough objects in the kitchen, and it does not become deformed... I love and can't give up it!"

CHEF CEYDA ARTUN

"We expect the environment we are in while cooking to help us. We can be comfortable and creative in the kitchen only in this way. I prefer the T-One. Because I can move more freely while cooking thanks to its ease of use, and the freedoms it offers."



CHEF CLAUDIO CHINALI

"I chose to use T-One for my kitchen because it is an extremely versatile product, resistant to any mistreatment such as pans hot, greasy and cuts... But above all because thanks to its design it is able to represent elegance and naturalness, the two main characteristics of my kitchen!"

T-One In The Spotlight: Chefs Share Their Thoughts / T-One



CHEF MAKSUT AŞKAR

"Being a chef is a part of my life rather than a job. I cook just to share this feeling with people. Because I believe that we should inspire each other. One of my biggest supporters in the kitchen is the T-One. Thanks to its durability, ease of use and aesthetic appearance, I can focus on creativity."

CHEF ŞEMSA DENİZSEL

"The T-One Porcelain Countertop is extremely practical! It does not allow acid stains and heat marks, the dough does not stick to it, and it can be easily cleaned... What else do we expect?"





CALACATTA UNIQUE

	mm	Soft Matte	Polished	Satin
162x323 cm	12 20		•	
160x320 cm	12 20		•	



CALACATTA UNIQUE OPENBOOK

	mm	Soft Matte	Polished	Satin
162x323 cm	12 20	•	•	
160x320 cm	12 20	•	•	



MARBLE STATUARIO MATTE

	mm	Soft Matte	Polished	Satin
162x323 cm	12 20		•	
160x320 cm	12 20		•	



PALISSANDRO MATTE

	mm	Soft Matte	Polished	Satin
162x323 cm	12 20	•		
160x320 cm	12 20	•		



CALACATTA GOLD

	mm	Soft Matte	Polished	Satin
162x323 cm	12 20	•		
160x320 cm	12 20		•	

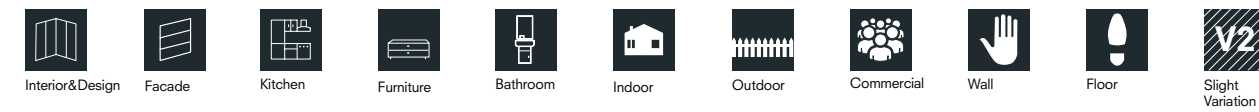
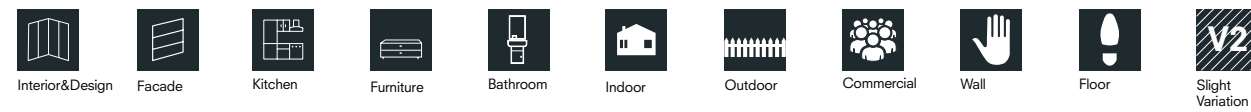



OLIMPO

	mm	Soft Matte	Polished	Satin
162x323 cm	12 20	•		
160x320 cm	12 20	•		



HIGHWAY BONE

	mm	Soft Matte	Polished	Satin
162x323 cm	12 20	•		
160x320 cm	12 20	•		



LUXURY CEMENT GREY

	mm	Soft Matte	Polished	Satin
162x323 cm	12 20	•		
160x320 cm	12 20			



VERSAILLES

	mm	Soft Matte	Polished	Satin
162x323 cm	12 20	•		
160x320 cm	12 20	•		



PORT LAURENT

	mm	Soft Matte	Polished	Satin
162x323 cm	12 20	•	•	
160x320 cm	12 20	•	•	

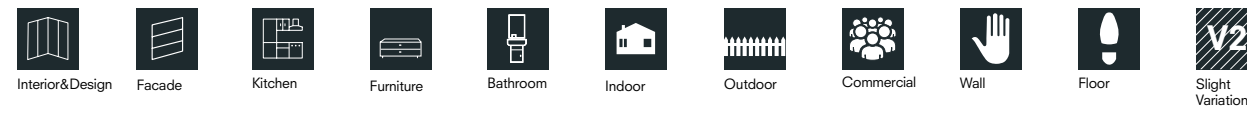
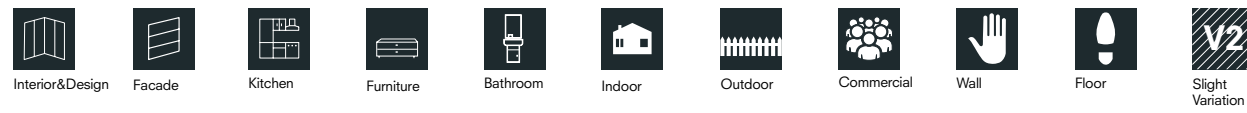



INDEX



A COMPLETE
PRODUCT
SYSTEM



PRODUCT
FINDER



LOOK



COMPANY



KALESINTERFLEX



T-ONE



TECHNICAL
SPECIFICATIONS

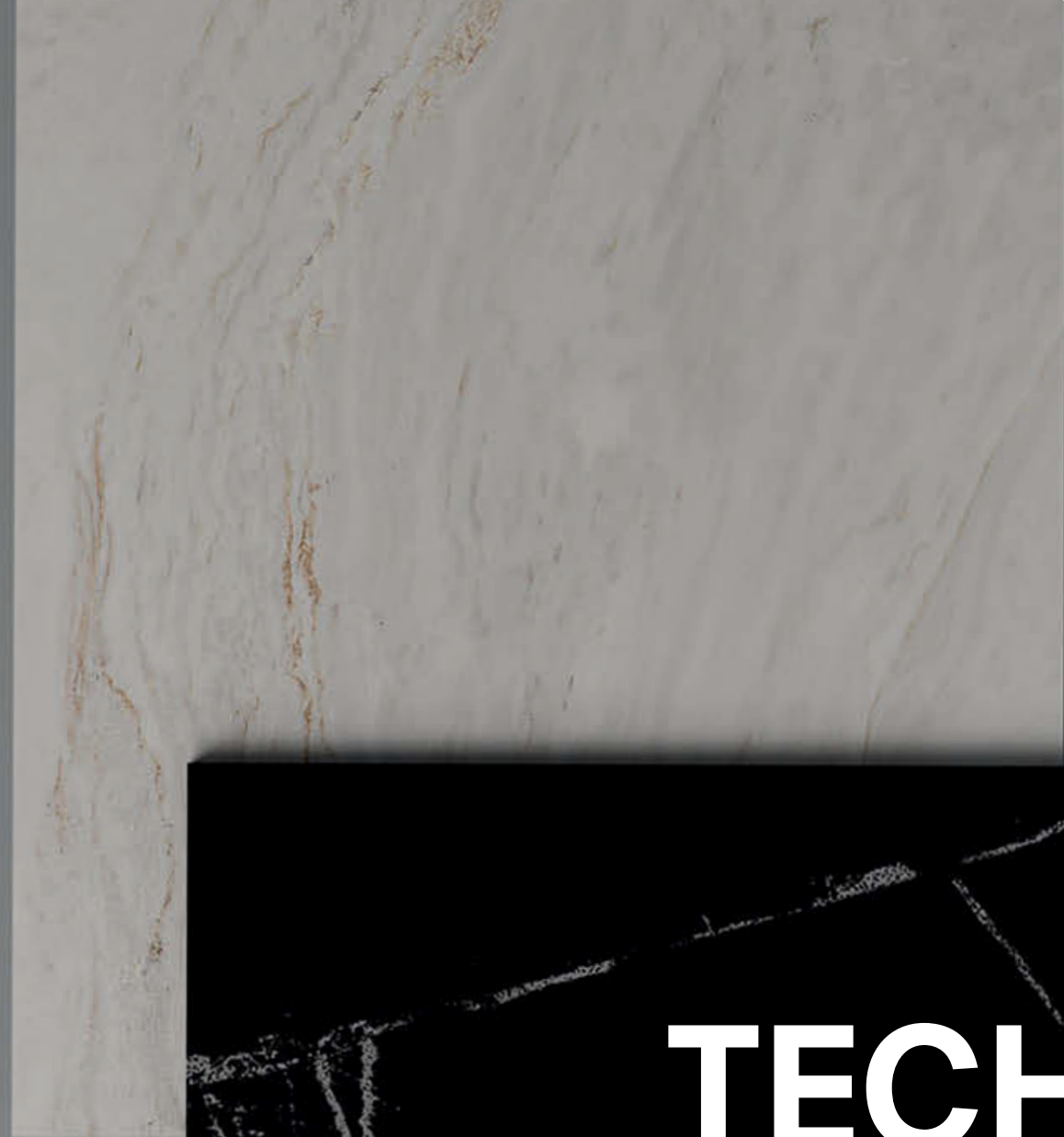

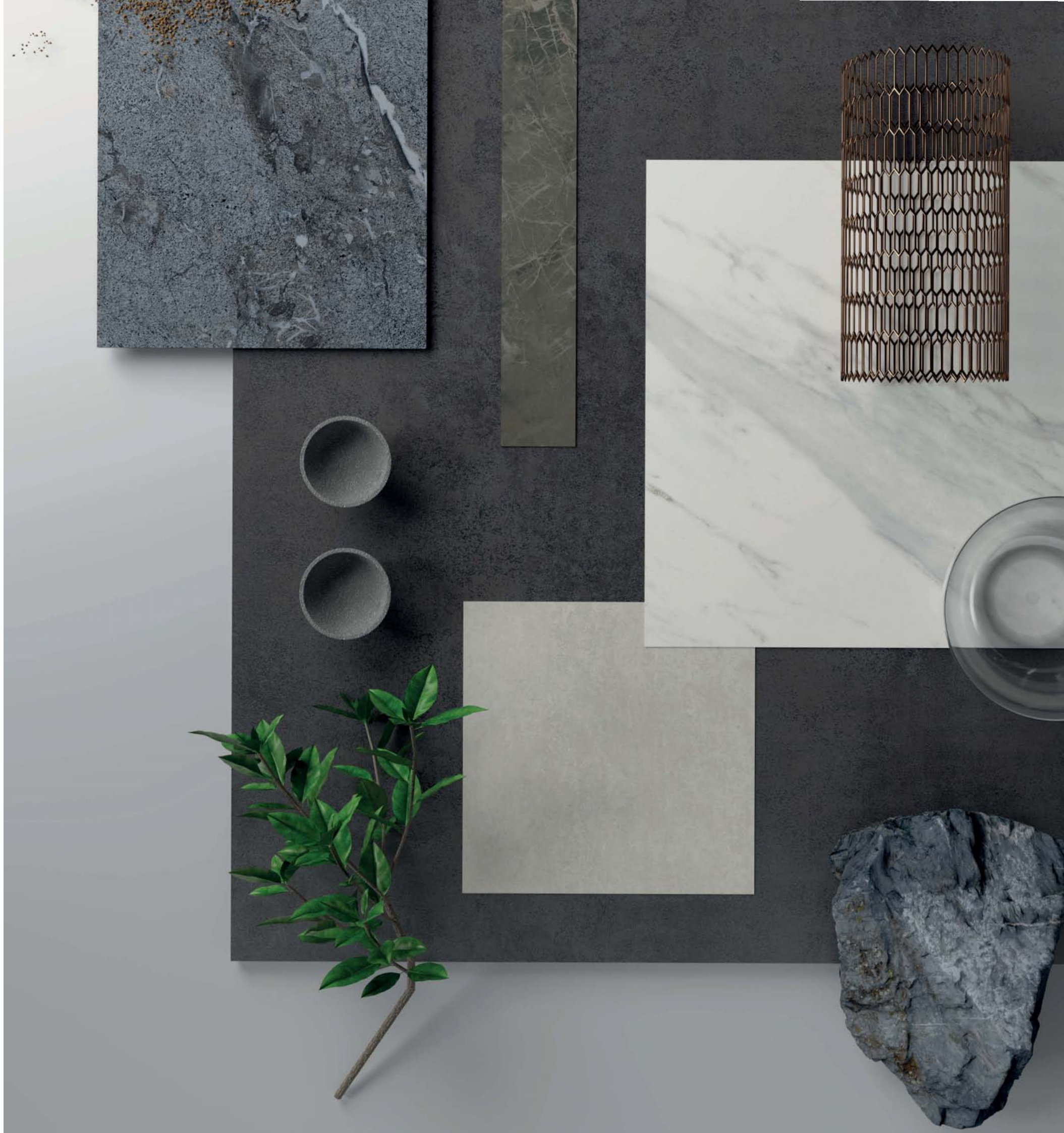
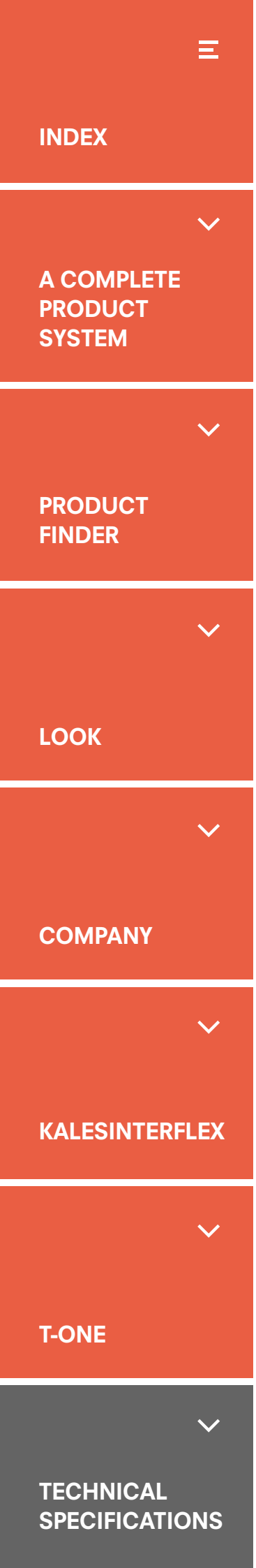

Technical Specifications

Kalesinterflex

- > Thicknesses - Sizes
- > Symbols
- > Kaleguard Defence
- > Services
- > Size Table
- > Packaging and Shipping Details
- > Technical Characteristics

T-One

- > Symbols
- > Technical Specifications

Thicknesses - Sizes / Kalesinterflex

Manufactured with thickness alternatives of **3mm, 5mm** and **6mm** Kalesinterflex effortlessly adapts to different areas of use.

Dimensions change, but quality remains the same.

Turkey's largest thin slab, Kalesinterflex allows for comfortable architecture with its standard dimension alternatives of **100x300cm, 120x360cm, 160x320cm** and **162x323cm**.

It may be cut and installed in any size as required by a project.

Standard Sizes

- 162x323cm - 63"x162" inches
- 160x320cm - 62.99"x125.98" inches
- 120x360cm - 48x144 inches
- 100x300cm - 40x120 inches

20mm



12mm



6mm



3mm



Symbols / Kalesinterflex

Everything that must be in a porcelain slab and more... Designed to shape the architecture of the future, Kalesinterflex is equipped with superior features to ensure flawless performance under any condition.



WEIGHT*

A 3mm-thick Kalesinterflex slab weighs 7kg/sqm while a 5mm-thick Kalesinterflex slab weighs 11.5kg/sqm.



ANTI-GRAFFITI

Easy to wipe and clean pollutants like crayon, graffiti, permanent marker, board marker.



DRILLING

Kalesinterflex can be drilled with glass drills as well as with other automatic drilling devices.

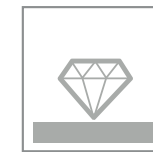

HIGH ABRASION RESISTANCE



FLEXIBILITY

The convex flexibility radius of a 3mm-thick Kalesinterflex Fit slab is 5.5m.

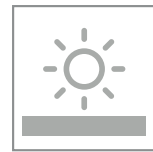

PHOTOCATALYTIC

Kalesinterflex is photocatalytic thanks to its Nano-tech coating surface. Kalesinterflex cleans itself with rain and sunlight.



HIGH HEAT AND FROST RESISTANCE

Kalesinterflex's surface is equipped with advanced technology to accommodate various climate conditions. It maintains its durability against sudden changes in heat and frost.

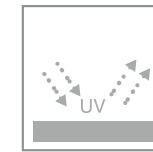

HIGH RESISTANCE TO UV RAYS



NON-FLAMMABLE (FLAME RESISTANT)

Kalesinterflex is totally fire resistant and non-flammable.



HYGIENIC

Protects both outdoor and indoor, even in poorly lit environment. Hygienic; resistant to bacteria, mould and fungus. The antibacterial feature of Kalesinterflex is approved by TÜBİTAK. (The Scientific and Technological Research Council of Turkey)



EASE OF CLEANING

Kalesinterflex has a smooth surface on which dirt does not accumulate. If required it can be cleaned with water and known cleaning agents.



LOW WATER ABSORPTION (NEAR ZERO)



CHEMICAL RESISTANCE

Kalesinterflex is resistant to chemicals (acids and bases) due to its porcelain ceramic structure and glaze layer on its surface.



ECO-FRIENDLY

Produced with an environmentally-friendly technology, Kalesinterflex has Ecospecifier certificate. Compared to the traditional ceramic production process, its gas and dust emission is 20 times, its CO2 emission is 1000 times less.



HIGH SCRATCH RESISTANCE



EVERLASTING

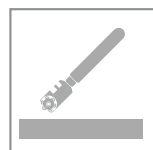

CUTTING

It can be cut with standard glass, ceramic cutters and computer controlled automatic cutting machines in the required dimensions.

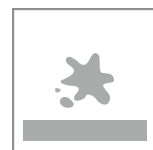

HIGH STAIN RESISTANCE

Kaleguard Defence / Kalesinterflex



Kaleguard
DEFENCE

Viruses have no place in your living space thanks to kaleguard defence!

Kalebodur products; which keep the spaces alive with functional products and inspire with unique ceramic collections; offer you and your loved ones a healthy life with antimicrobials.

Healthy living spaces in all parts of life!

With Kaleguard Defence, there is no virus and bacteria; there is healthy and comfortable life. You can safely touch ceramic surfaces with Kaleguard Defence; guaranteed and certified by national and international organisations.



Thanks to Kaleguard assurance, there is hygiene and health on the surfaces you contact.



Kaleguard Defence Protection
Provides effective protection against viruses and bacteria.



Environment-friendly
It has no harmful effect on the environment.



Hygienic
It has stain resistance. In this way, surfaces can be cleaned easily.



Invisible Surface Application
Since it can be applied very thin, the aesthetic properties of the product do not deform.

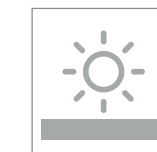

Chemical Resistance
It has chemical resistance. It does not corrode due to cleaners.

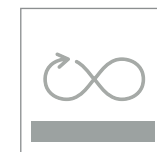

Long-lasting
It preserves its antimicrobial features for 2 years in wall and floor applications.



INDEX



A COMPLETE
PRODUCT
SYSTEM



PRODUCT
FINDER



LOOK



COMPANY



KALESINTERFLEX



T-ONE



TECHNICAL
SPECIFICATIONS

Services / Kalesinterflex

Houses, offices, shopping malls, and airports...We see all of them as meeting points where we touch life. We carry the care we take while producing our designs to product applications, and we aim to make our entire operation process, from production to implementation, perfect.

We provide technical support for the smooth progress of field applications and work with the practitioners in coordination to supervise compliance with the specifications.

With the help of our expert technical sales staff, we guide the sales processes by ensuring the right product, practitioner, and project matches in facade projects.

Working in cooperation with the relevant departments and staff of the universities, specific to our product groups, we ensure that technical details and specifications are prepared and shared. We come together with stakeholders such as architects, contractors, and facade practitioners, share with them technical specifications, principle detail drawings, and static calculation studies in accordance with our products, and offer technical guidance in special detail and grid works.

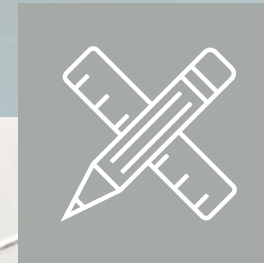

Size Table / Kalesinterflex

TYPOLOGY	Series	Color	100x300cm	120x360cm	160x320cm			162x323cm			162x323cm			80x280cm	OPENBOOK	TECHNOLOGY
			3mm	3mm	6mm			12mm			20mm			6mm		6- 12 20mm
			MATTE	MATTE	SOFT MATTE	POLISHED	SATIN	SOFT MATTE	POLISHED	SATIN	SOFT MATTE	POLISHED	ROCK SURFACE	SOFT MATTE		
MARBLE BLACK AND WHITE	MARBLES	CALACATTA 2.O	X	X												
MARBLE BLACK AND WHITE	CALCATTIA UNIQUE	CALCATTIA UNIQUE NEW	X	X	X	X			X	X	X			X		FLOWTECH
MARBLE BLACK AND WHITE	CALCATTIA CALDIA	CALCATTIA CALDIA NEW	X	X	X	X			X	X	X					
MARBLE BLACK AND WHITE	CALACATTA GOLD	CALACATTA GOLD	X	X	X	X			X	X	X					
MARBLE BLACK AND WHITE	MARBLES	CALACATTA ICE	X	X												
MARBLE BLACK AND WHITE	FLORENCE	FLORENCE NEW			X	X			X	X				X		FLOWTECH
MARBLE BLACK AND WHITE	GOLDEN HOUR	GOLDEN HOUR NEW			X	X			X	X				X		FLOWTECH
MARBLE BLACK AND WHITE	BRONZE LINE	BRONZE LINE NEW				X			X	X						
MARBLE BLACK AND WHITE	CALACATTA VIOLA	CALACATTA VIOLA NEW							X	X						
MARBLE BLACK AND WHITE	CALACATTA MACCHIA	CALACATTA MACCHIA			X	X			X	X						
MARBLE BLACK AND WHITE	MARBLES	COLORODO ORO	X											X		
MARBLE BLACK AND WHITE	MARBLES	LIMESTONE	X	X												
MARBLE BLACK AND WHITE	MARBLES	MARBLE DARK	X	X												
MARBLE BLACK AND WHITE	PIETRA NERO	PIETRA NERO NEW	X	X	X	X			X	X				X		
MARBLE BLACK AND WHITE	PALISSANDRO	PALISSANDRO	X	X	X				X							
MARBLE BLACK AND WHITE	PORT LAURENT	PORT LAURENT	X		X	X			X	X						
MARBLE BLACK AND WHITE	SAHARA BROWN	SAHARA BROWN	X		X				X							
MARBLE BLACK AND WHITE	MARBLES	WINTERLAND	X	X												
MARBLE EXCLUSIVE	MARBLES	MARBLE STATUARIO							X							
MARBLE EXCLUSIVE	MARBLES	ALAMEDA	X	X												
MARBLE EXCLUSIVE	MARBLES	ASTEROID	X	X												
MARBLE EXCLUSIVE	MARMO METALLO	MARMO METALLO	X	X	X				X							FLOWTECH
MARBLE EXCLUSIVE	MARBLES	MOCHA PERLA	X	X												
MARBLE EXCLUSIVE	MARBLES	OLIMPO	X	X	X	X			X	X						
MARBLE EXCLUSIVE	SARRANCOLIN	SARRANCOLIN NEW			X	X			X	X						FLOWTECH
MARBLE EXCLUSIVE	DIAMOND COLLECTION	SKYNEW				X										FLOWTECH
MARBLE EXCLUSIVE	PATAGONIA	PATAGONIA NEW				X			X	X				X		FLOWTECH
MARBLE EXCLUSIVE	QUARZITE J'ADORE	QUARZITE J'ADORE NEW			X	X			X	X				X		FLOWTECH
MARBLE EXCLUSIVE	MARBLES	ONICE AGATHE				X										
MARBLE EXCLUSIVE	MARBLES	VERSAILLES							X							
MARBLE EXCLUSIVE	MARINA	MARINA NEW					X			X						FLOWTECH
MARBLE EXCLUSIVE	ALASKA WHITE	ALASKA WHITE NEW					X			X						FLOWTECH
MARBLE EXCLUSIVE	VERDE LUNA	VERDE LUNA - SOON					X							X		FLOWTECH
MARBLE EXCLUSIVE	SUPERLATIVA	SUPERLATIVA - SOON					X			X						FLOWTECH
MARBLE EXCLUSIVE	TIFFANY BLUE	TIFFANY BLUE - SOON					X							X		FLOWTECH
MARBLE EXCLUSIVE	NAMIBIA	NAMIBIA - SOON					X			X						FLOWTECH
MARBLE TIMELESS	MARBLES	PULPIS	X	X												
MARBLE TIMELESS	MARBLES	SAVANA DARK														
MARBLE TIMELESS	FIORI DI BOSCO	FIORI DI BOSCO NEW			X	X			X	X						FLOWTECH
MARBLE TIMELESS	DIAMOND COLLECTION	DENISE NEW					X			X						GLOWTECH
MARBLE TIMELESS	MARBLES	TRANSLUCENT	X													
MARBLE TIMELESS	ONICE	ONICE NEW					X			X						
MARBLE TIMELESS	DIAMOND COLLECTION	CRISTALUS NEW					X			X						GLOWTECH
STONE	C-STONE	C-STONE ANTHRACITE	X	X												
STONE	C-STONE	C-STONE BEIGE	X	X												
STONE	C-STONE	C-STONE WHITE	X	X												
STONE	C-STONE	C-STONE GREY	X	X												
STONE	C-STONE	C-STONE BROWN	X	X												
STONE	KSF UPTOWN	UPTOWN DARK	X	X												
STONE	KSF UPTOWN	UPTOWN LIGHT	X	X												
STONE	NATURAL STONE	BRERA CRÈME	X													
STONE	NATURAL STONE	LECCESE DARK SAND	X	X												
STONE	NATURAL STONE	LECCESE GREY	X													
STONE	NATURAL STONE	LECCESE LIGHT SAND	X													

Size Table / Kalesinterflex

TYPOLOGY	Series	Color	100x300cm	120x360cm	160x320cm			162x323cm			162x323cm			80x280cm	OPENBOOK	TECHNOLOGY
			3mm	3mm	6mm			12mm			20mm			6mm		6- 12 20mm
			MATTE	MATTE	SOFT MATTE	POLISHED	SATIN	SOFT MATTE	POLISHED	SATIN	SOFT MATTE	POLISHED	ROCK SURFACE	SOFT MATTE		
STONE	NATURAL STONE	PIETRA BLUE	X	X							X		X			
STONE	NATURAL STONE	PIETRA GREY	X								X		X			
STONE	OCEAN	OCEAN BLACK	X						X							
STONE	OCEAN	OCEAN WHITE	X						X							
STONE	OMNITECH	PIAMONTE NEW	X	X					X							BODYTECH
STONE	OMNITECH	MONOLITH NEW	X	X					X							BODYTECH
STONE	PIETRA BASALTINA	PIETRA BASALTINA	X								X		X			FORMTECH
STONE	PIETRA DI CHATIL	PIETRA CHATILLONN	X													
STONE	STONE GALLERY	QUARTZ ASH	X													
STONE	CALCARIO COLLECTION	CALCARIO COLLECTION NEW			X				X				X			BODYTECH,FORMTECH
STONE	STONELAND	PIETRA DI GREY	X	X	X				X			X				
STONE	TERRAZZO	TERRAZZO														
STONE	EARTH COLLECTION	TRAVERTINE NEW	X	X	X				X							FORMTECH
STONE	EARTH COLLECTION	RAPOLANO NEW	X	X	X				X							FORMTECH
STONE	MERCURY	MERCURY							X							
METALLIC	OXIDO	OXIDO FLAME	X	X												
METALLIC	OXIDO	OXIDO ICE	X	X												
METALLIC	OXIDO	OXIDO OIL	X	X												
METALLIC	OXIDO	OXIDO MOSS	X	X												
METALLIC	METALLIC	METALLIC ANTHRACITE	X						X							
METALLIC	METALLIC	METALLIC CORE	X						X							
METALLIC	CORTEN	CORTEN - SOON			X											FORMTECH
METALLIC	FERRO	FERRO - SOON	X						X							
METALLIC	STEEL	STEEL - SOON	X						X							
CEMENT	HIGHWAY	HIGHWAY BONE	X						X							
CEMENT	HUED	HUED ANTHRACITE	X	X												
CEMENT	HUED	HUED GREY	X	X												
CEMENT	HUED	HUED DARK GREY	X	X												
CEMENT	HUED	HUED OFF WHITE	X	X												
CEMENT	LUXURY CEMENT	LUXURY CEMEMNT WHITE NEW	X	X	X				X							
CEMENT	LUXURY CEMENT	LUXURY CEMEMNT ANTHI	X	X	X				X							
CEMENT	LUXURY CEMENT	LUXURY CEMEMNT ANTHRACITE	X	X	X				X							
CEMENT	LUXURY CEMENT	LUXURY CEMEMNT BEIGE	X	X	X				X							
CEMENT	LUXURY CEMENT	LUXURY CEMEMNT	X	X	X											
CEMENT	LUXURY CEMENT	LUXURY CEMEMNT GREY	X	X	X				X							
CEMENT	LUXURY CEMENT	LUXURY CEMEMNT TAUPE	X	X	X				X							
CEMENT	LUXURY CEMENT	LUXURY CEMEMNT MINK	X	X	X				X							
CEMENT	ARCHE	ARCHE NEW	X													
DESIGN COLLECTION	ARTWALL	BLUE BLOSSOMS - SOON												X		DECOTECH
DESIGN COLLECTION	ARTWALL	LIQUID - SOON												X		DECOTECH
DESIGN COLLECTION	ARTWALL	JASMINE - SOON												X		DECOTECH
DESIGN COLLECTION	ARTWALL	LACE - SOON												X		DECOTECH
DESIGN COLLECTION	ARTWALL	MOONDUST - SOON												X		DECOTECH
WOOD	ARTWALL	ARTEMIS - SOON												X		DECOTECH
WOOD	HOLLYWOOD	HOLLYWOOD BEIGE	X	X												
WOOD	HOLLYWOOD	HOLLYWOOD BROWN		X												
WOOD	PLANK	PLANK 104	X													
WOOD	PLANK	PLANK 110	X													
WOOD	PLANK	PLANK 111	X													
WOOD	PLANK	PLANK 114	X													
WOOD	SHELL WOOD	SHELL WOOD DARK	X	X												

Packaging and Shipping Details / Kalesinterflex

Product Size cm	Pallet Size cm	Product Group	Pallet Detail			Trailer			20' Container			40' Container		
			Units per Item	Product m ²	Gross kg	Units per Pallet	Total m ²	Gross kg	Units per Pallet	Total m ²	Gross kg	Units per Pallet	Total m ²	Gross kg
100X300cm	114X317X40	3MM PLAIN	50	150,00	1.365	19	2.850	25.935	10	1.500	13.650	19	2.850	25.935
100X300cm	114X317X40	6MM PLAIN	30	90,00	1.440	18	1.620	25.920	10	900	14.400	18	1.620	25.920
100X300cm	114X317X40	3MM FIT	45	135,00	1.260	20	2.700	25.200	10	1.350	12.600	19	2.565	23.940
100X300cm	114X317X40	6MM FIT	26	78,00	1.350	19	1.482	25.650	10	780	13.500	18	1.404	24.300
100X300cm	114X317X40	3+3 LAMINEX	26	78,00	1.350	19	1.482	25.650	10	780	13.500	18	1.404	24.300
100X300cm	114X317X40	6+6 LAMINEX	14	42,00	1.440	18	756	25.920	10	420	14.400	18	756	25.920
100X150cm	113X163X40	3MM PLAIN	50	75,00	615	36	2.700	22.140	30	2.250	18.450	36	2.700	22.140
100X150cm	113X163X40	6MM PLAIN	30	45,00	720	36	1.620	25.920	30	1.350	21.600	36	1.620	25.920
100X150cm	113X163X40	3MM FIT	45	67,50	630	36	2.430	22.680	30	2.025	18.900	36	2.430	22.680
100X150cm	113X163X40	6MM FIT	26	39,00	675	36	1.404	24.300	30	1.170	20.250	36	1.404	24.300
100X150cm	113X163X40	3+3 LAMINEX	26	39,00	675	36	1.404	24.300	30	1.170	20.250	36	1.404	24.300
100X150cm	113X163X40	6+6 LAMINEX	14	21,00	720	36	756	25.920	30	630	21.600	36	756	25.920
100X100cm	113X113X40	3MM PLAIN	50	50,00	410	50	2.500	20.500	50	2.500	20.500	50	2.500	20.500
100X100cm	113X113X40	6MM PLAIN	30	30,00	480	50	1.500	24.000	50	1.500	24.000	50	1.500	24.000
100X100cm	113X113X40	3MM FIT	45	45,00	420	50	2.250	21.000	50	2.250	21.000	50	2.250	21.000
100X100cm	113X113X40	6MM FIT	26	26,00	450	50	1.300	22.500	50	1.300	22.500	50	1.300	22.500
100X100cm	113X113X40	3+3 LAMINEX	26	26,00	450	50	1.300	22.500	50	1.300	22.500	50	1.300	22.500
100X100cm	113X113X40	6+6 LAMINEX	14	14,00	480	50	700	24.000	50	700	24.000	50	700	24.000
50X300cm	114X317X40	3MM PLAIN	100	150,00	1.230	19	2.850	23.370	10	1.500	12.300	19	2.850	23.370
50X300cm	114X317X40	6MM PLAIN	60	90,00	1.440	19	1.710	27.360	10	900	14.400	18	1.620	25.920
50X300cm	114X317X40	3MM FIT	90	135,00	1.260	20	2.700	25.200	10	1.350	12.600	19	2.565	23.940
50X300cm	114X317X40	6MM FIT	52	78,00	1.350	19	1.482	25.650	10	780	13.500	18	1.404	24.300
50X300cm	114X317X40	3+3 LAMINEX	52	78,00	1.350	19	1.482	25.650	10	780	13.500	18	1.404	24.300
50X300cm	114X317X40	6+6 LAMINEX	28	42,00	1.440	19	798	27.360	10	420	14.400	18	756	25.920
50X150cm	113X163X40	3MM PLAIN	100	75,00	615	36	2.700	22.140	30	2.250	18.450	36	2.700	22.140
50X150cm	113X163X40	6MM PLAIN	60	45,00	720	36	1.620	25.920	30	1.350	21.600	36	1.620	25.920
50X150cm	113X163X40	3MM FIT	90	67,50	630	36	2.430	22.680	30	2.025	18.900	36	2.430	22.680
50X150cm	113X163X40	6MM FIT	52	39,00	675	36	1.404	24.300	30	1.170	20.250	36	1.404	24.300
50X150cm	113X163X40	3+3 LAMINEX	52	39,00	675	36	1.404	24.300	30	1.170	20.250	36	1.404	24.300
50X150cm	113X163X40	6+6 LAMINEX	28	21,00	720	36	756	25.920	30	630	21.600	36	756	25.920
50X100cm	113X113X40	3MM PLAIN	100	50,00	410	50	2.500	20.500	50	2.500	20.500	50	2.500	20.500
50X100cm	113X113X40	6MM PLAIN	60	30,00	480	50	1.500	24.000	50	1.500	24.000	50	1.500	24.000
50X100cm	113X113X40	3MM FIT	90	45,00	420	50	2.250	21.000	50	2.250	21.000	50	2.250	21.000
50X100cm	113X113X40	6MM FIT	52	26,00	450	50	1.300	22.500	50	1.300	22.500	50	1.300	22.500
50X100cm	113X113X40	3+3 LAMINEX	52	26,00	450	50	1.300	22.500	50	1.300	22.500	50	1.300	22.500
50X100cm	113X113X40	6+6 LAMINEX	28	14,00	480	50	700	24.000	50	700	24.000	50	700	24.000

Product Size cm	Pallet Size cm	Product Group	Pallet Detail			Trailer			20' Container			40' Container		
			Units per Item	Product m ²	Gross kg	Units per Pallet	Total m ²	Gross kg	Units per Pallet	Total m ²	Gross kg	Units per Pallet	Total m ²	Gross kg
120X360cm	134X377X34	3MM PLAIN	40	172,80	1.430	15	2.592	21.444	5	864	7.148	15	2.592	21.444
120X360cm	134X377X34	6MM PLAIN	22	95,04	1.551	15	1.426	23.258	5	475	7.753	15	1.426	23.258
120X360cm	134X377X34	3MM FIT	35	151,20	1.430	15	2.268	21.444	5	756	7.148	15	2.268	21.444
120X360cm	134X377X34	6MM FIT	20	86,40	1.516	15	1.296	22.740	5	432	7.580	15	1.296	22.740
120X360cm	134X377X34	3+3 LAMINEX	20	86,40	1.516	15	1.296	22.740	5	432	7.580	15	1.296	22.740
120X360cm	134X377X34	6+6 LAMINEX	10	43,20	1.516	15	648	22.740	5	216	7.580	15	648	22.740
120X180cm	134X193X34	3MM PLAIN	40	86,40	715	30	2.592	21.444	20	1.728	14.296	30	2.592	21.444
120X180cm	134X193X34	6MM PLAIN	22	47,52	775	30	1.426	23.258	20	950	15.506	30	1.426	23.258
120X180cm	134X193X34	3MM FIT	35	75,60	715	30	2.268	21.444	20	1.512	14.296	30	2.268	21.444
120X180cm	134X193X34	6MM FIT	20	43,20	758	30	1.296	22.740	20	864	15.160	30	1.296	22.740
120X180cm	134X193X34	3+3 LAMINEX	20	43,20	758	30	1.296	22.740	20	864	15.160	30	1.296	22.740
120X180cm	134X193X34	6+6 LAMINEX	10	21,60	758	30	648	22.740	20	432	15.160	30	648	22.740
120X120cm	134X134X34	3MM PLAIN	40	57,60	483	50	2.880	24.160	20	1.152	9.664	45	2.592	21.744
120X120cm	134X134X34	6MM PLAIN	22	31,68	524	50	1.584	26.176	20	634	10.470	45	1.426	23.558
120X120cm	134X134X34	3MM FIT	35	50,40	483	50	2.520	24.160	20	1.008	9.664	45	2.268	21.744
120X120cm	134X134X34	6MM FIT	20	28,80	512	50	1.440	25.600	20	576	10.240	45	1.296	23.040
120X120cm	134X134X34	3+3 LAMINEX	20	28,80	512	50	1.440	25.600	20	576	10.240	45	1.296	23.040
120X120cm	134X134X34	6+6 LAMINEX	10	14,40	512	50	720	25.600	20	288	10.240	45	648	23.040
60X360cm	134X377X34	3MM PLAIN	80	172,80	1.430	15	2.592	21.444	5	864	7.148	15	2.592	21.444
60X360cm	134X377X34	6MM PLAIN	44	95,04	1.551	15	1.426	23.258	5	475	7.753	15	1.426	23.258
60X360cm	134X377X34	3MM FIT	70	151,20	1.430	15	2.268	21.444	5	756	7.148	15	2.268	21.444
60X360cm	134X377X34	6MM FIT	40	86,40	1.516	15	1.296	22.740	5	432	7.580	15	1.296	22.740
60X360cm	134X377X34	3+3 LAMINEX	40	86,40	1.516	15	1.296	22.740	5	432	7.580	15	1.296	22.740
60X360cm	134X377X34	6+6 LAMINEX	20	43,20	1.516	15	648	22.740	5	216	7.580	15	648	22.740
60X180cm	134X193X34	3MM PLAIN	80	86,40	715	30	2.592	21.444	20	1.728	14.296	30	2.592	21.444
60X180cm	134X193X34	6MM PLAIN	44	47,52	775	30	1.426	23.258	20	950	15.506	30	1.426	23.258
60X180cm	134X193X34	3MM FIT	70	75,60	715	30	2.268	21.444	20	1.512	14.296	30	2.268	21.444
60X180cm	134X193X34	6MM FIT	40	43,20	758	30	1.296	22.740	20	864	15.160	30	1.296	22.740
60X180cm	134X193X34	3+3 LAMINEX	40	43,20	758	30	1.296	22.740	20	864	15.160	30	1.296	22.740
60X180cm	134X193X34	6+6 LAMINEX	20	21,60	758	30	648	22.740	20	432	15.160	30	648	22.740



INDEX



A COMPLETE
PRODUCT
SYSTEM



PRODUCT
FINDER



LOOK



COMPANY



KALESINTERFLEX



T-ONE



TECHNICAL
SPECIFICATIONS

Packaging and Shipping Details / Kalesinterflex

Technical Manual For Kalesinterflex Porcelain Slab
Packaging / Loading / Carrying Practices

Packaging And Packages

A-Frame

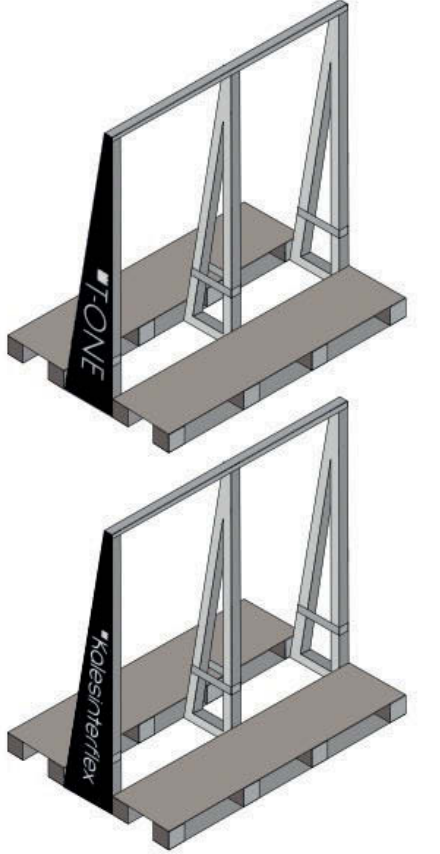
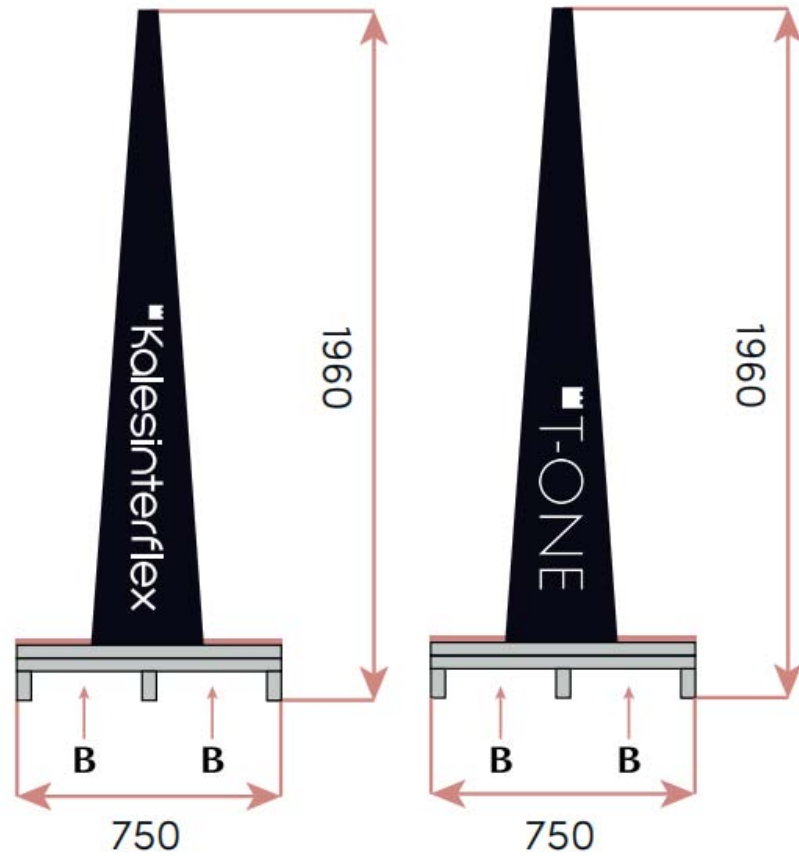
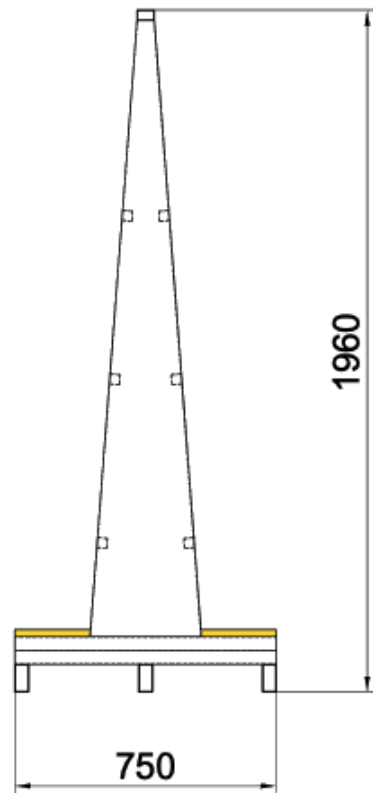
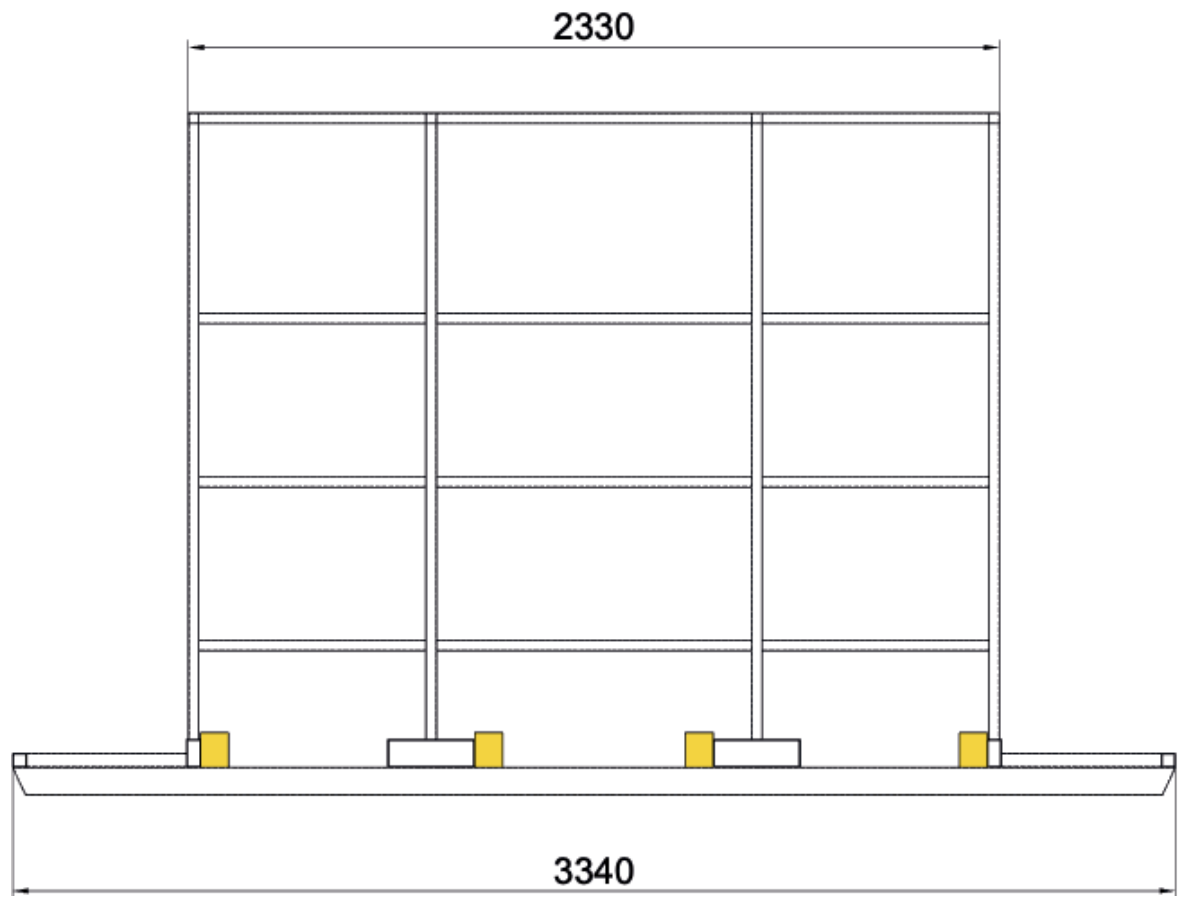

Packaging and Shipping Details / Kalesinterflex

Quantity, Kilogram and Size Information of A-Frame;

Format/mm (vertical stacking)	Thickness (mm)	Pcs for A-Frame (Pcs/A-Frame)	M2 for A-Frame	Kg for A-Frame (A-Frame is included)	Full Size of A-Frame (cm)
Kaleinterflex 6mm Full Length* 1620x3230 mm 63.7"x127.7"	6	44	230.2344	3335	328x76x197h
Kaleinterflex 12mm Full Length* 1620x3230 mm 63.7"x127.7"	12	24	125.5824	3763	328x76x197h
Kaleinterflex 20mm Full Length* 1620x3230 mm 63.7"x127.7"	20	12	62.7912	3101	328x76x197h

*"Furnace Slab" having untrimmed format. 5,2326 m2/piece-Empty A-Frame 121kg (metal)

Information Regarding the A-Frame Carrying Capacities of Containers and Trucks

Container Loading with A-frame (1620x3230 mm (63.7"x127.7"))									
Container Type	20" Container			40" Container			Truck (13.60m)		
The Thickness of the Slab (mm)	6	12	20	6	12	20	6	12	20
A-Frame That Can Be Loaded (Pieces)	3	3	3	7	7	7	7	7	7
Slabs That Can Be Loaded (Pcs)	132	72	36	308	168	84	308	168	84
Loadable Area (m2)	690.7	376.75	188.37	1611.64	879.08	439.54	1611.64	879.08	439.54
Maximum Total Weight (kg)	10.000	11.289	9.304	23.343	26.341	21.709	23.343	26.341	21.709

* Empty weight of A-Frame 121kg (metal)



Packaging and Shipping Details / Kalesinterflex

1. Carrying And Storing

Kalesinterflex 1620x3230mm slabs should be carried in safe conditions to protect their original appearance and prevent accidental damage. It is recommended to be careful and make sure that the carrying area is closed to pedestrians while the product is carried.

1.1 Carrying A-Frame With a Forklift

A-Frame should be symmetrically loaded before carrying to prevent balance problems. Before carrying, the operator should always check that the slabs are fixed to A-Frame with special tapes. It is recommended to be careful while carrying the slabs loaded on the A-Frame since they are not protected at the points corresponding to the outer edges.

A-Frames are equipped with two gripping points to be carried with a forklift: The distance between the forklift's forks for "A" front gripping point is 740 mm. The distance between the forks for the "B" lateral gripping point is 500mm.

If both A and B lateral loading points are to be used, a forklift that has 8000 kg. maximum load capacity is recommended. The Kalesinterflex slabs loaded on the A-Frame in the warehouse or near the transformer should be preferably carried by using the "A" front gripping point. In other words, the process should be carried out by using a 3230 mm A-Frame, to which the products are to be fixed, and a forklift that has 1200 mm long forks at least, and a 5000-8000 kg load capacity. If the 'B' gripping point is to be used, a forklift that has an 8000 kg load capacity and at least 2800 mm forks should be used.

It should be ensured that the load does not move on the forks. While loading and unloading trucks and containers, fix A-Frame with the help of the two "A" and "B" gripping points in the way specified in the following paragraphs, respectively. While loading/unloading the trucks and containers and carrying even a single slab, fix the slabs to A-Frame with cloth or plastic tapes/straps. Metal chains should not be used at this stage.

Before the slabs are taken out from the A-Frame, it is necessary to place it on a flat surface having no defects that may cause the slab (s) to fall.

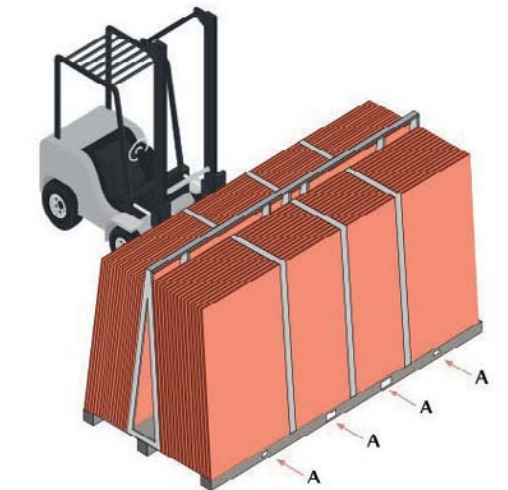

Forklift with 8000 kg
Capacity to carry from direction B

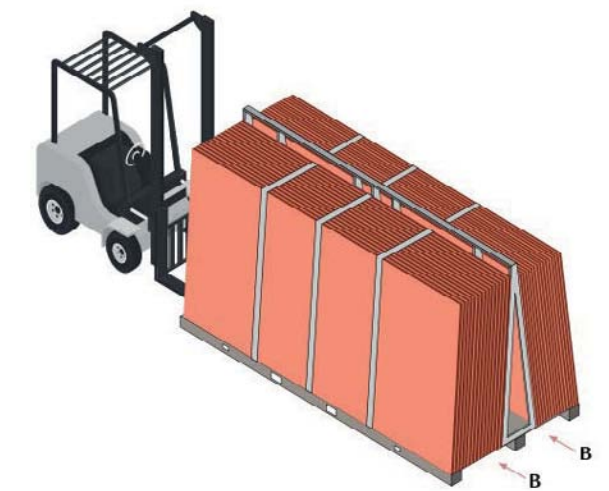

Forklift with 5000 kg
Capacity to carry from direction A

Packaging and Shipping Details / Kalesinterflex

1.1.1. Loading/Unloading the Truck with A-Frame

To load and unload the trucks which have dropside bodies, fix the A-Frame by placing the forklift forks at two “A” gripping points and leaving at least a distance of 740 mm between them. Forklift forks with a minimum length of 1200 mm should be used to place the A-Frame in the middle of the truck.

To safely carry the products on the vehicles, fix the A-Frames to the truck bed from the base and top. Use polyester or similar straps for this work. If you load several rows of A-Frames, you should leave a distance of at least 50 mm between them.

During loading and unloading, the operator should be careful about the people around. A-Frame should always be kept low while being carried and only be lifted when it is very close to the truck. You will find below an example of loading an A-Frame on a truck with a standard length of 13.60 m.

Wooden boards having at least 7x9 cm sizes, which are placed in the forklift lifting slots, are used to bolster the A-frames.

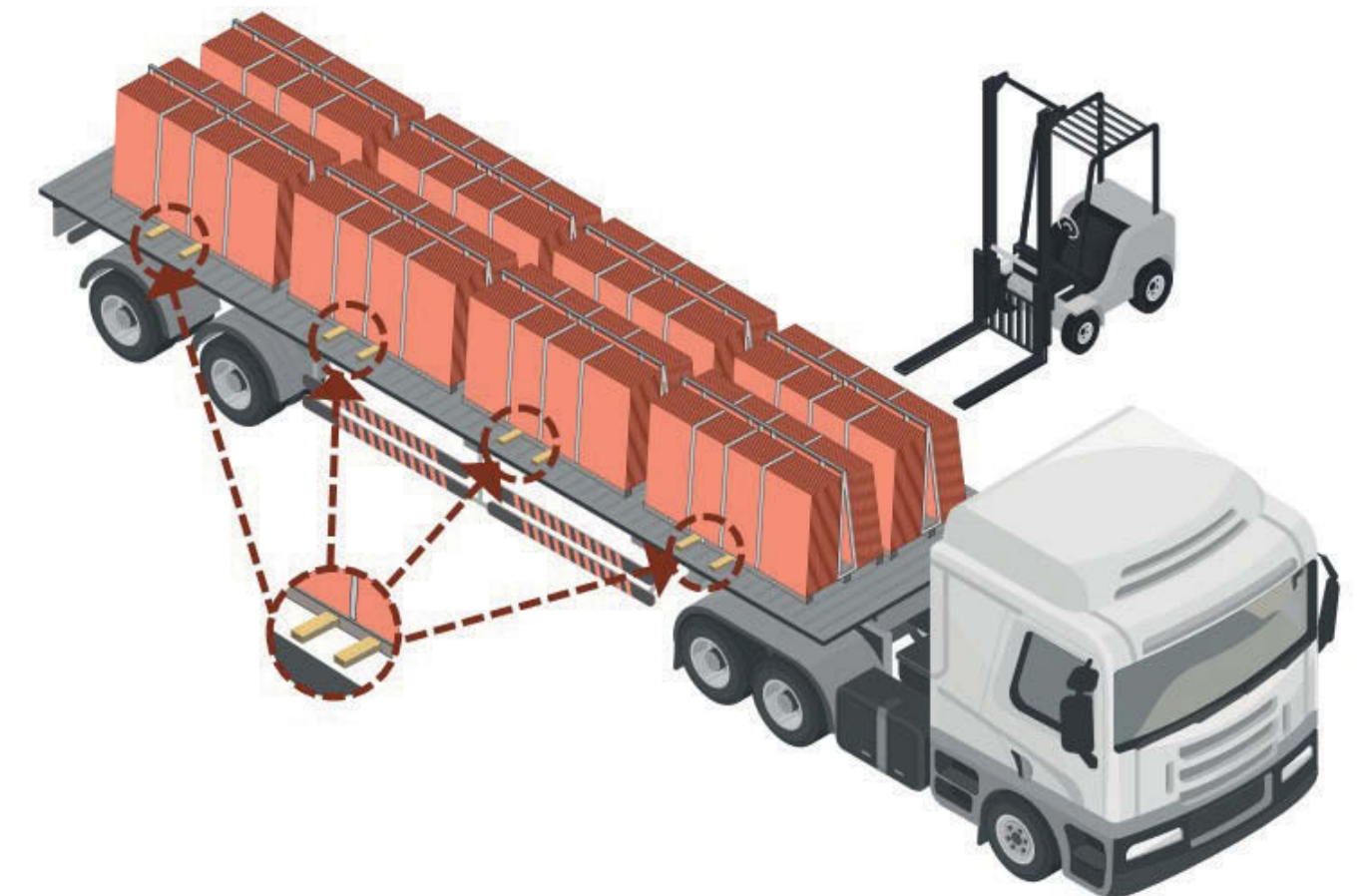
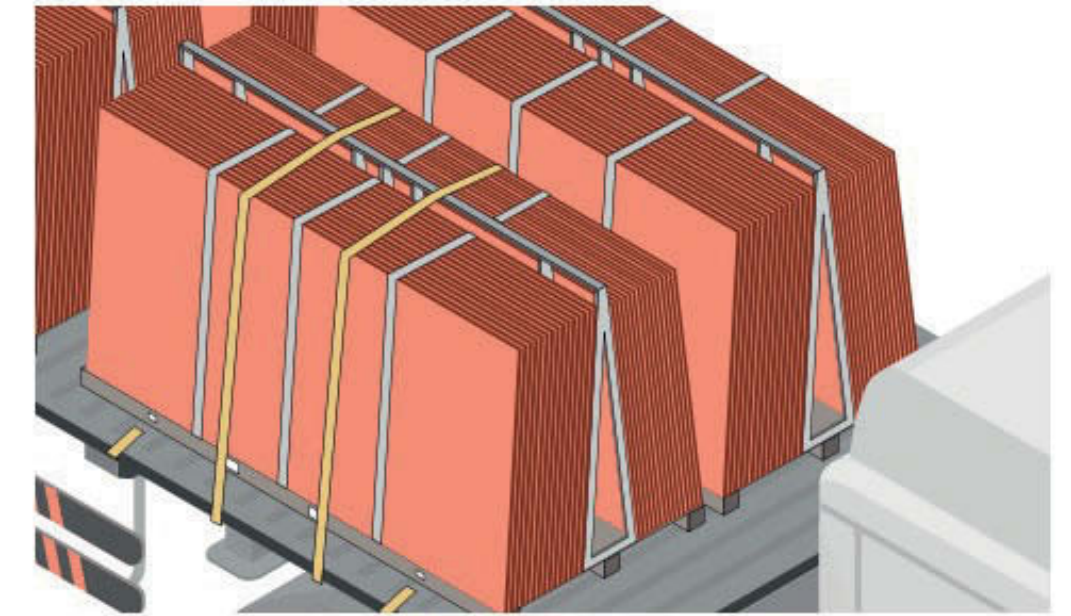

INDEX

A COMPLETE
PRODUCT
SYSTEM

PRODUCT
FINDER

LOOK

COMPANY

KALESINTERFLEX

T-ONE

TECHNICAL
SPECIFICATIONS

Packaging and Shipping Details / Kalesinterflex

1.1.2. Domestic and International Highway Transportation With Truck Highway Transportation

In international transportation with trucks, two A-Frames are fixed to the vehicle chassis with at least two safety ropes. Airbag or styrofoam is used as a bolster between the two A-Frames.

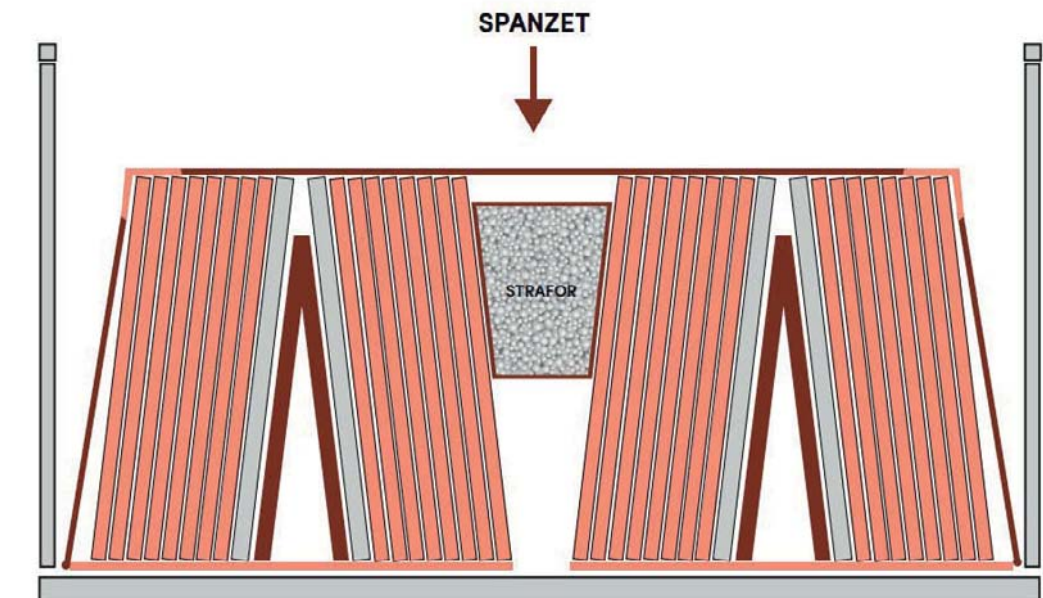

1.1.3. Loading/Unloading Container With A-Frame

Use a pallet jack or forklift with a 5000 kg load capacity and forks of at least 2800 mm while the products are loaded on the container, and the container is unloaded. The operator moves the loaded A-Frame after taking and lifting the load with the help of the two "B" gripping points.

During loading, check the balance of the product by fixing the A-Frames to each other and the towing platform. To carry the frames safely on the container, fill the gaps between the scaffolds and between the scaffold rows and airbags.

Before the unloading, always check the methods used while locking the A-Frames, to remove the locks. Outside the container, carry the product by attaching the A-Frames to the "A" gripping point every time.

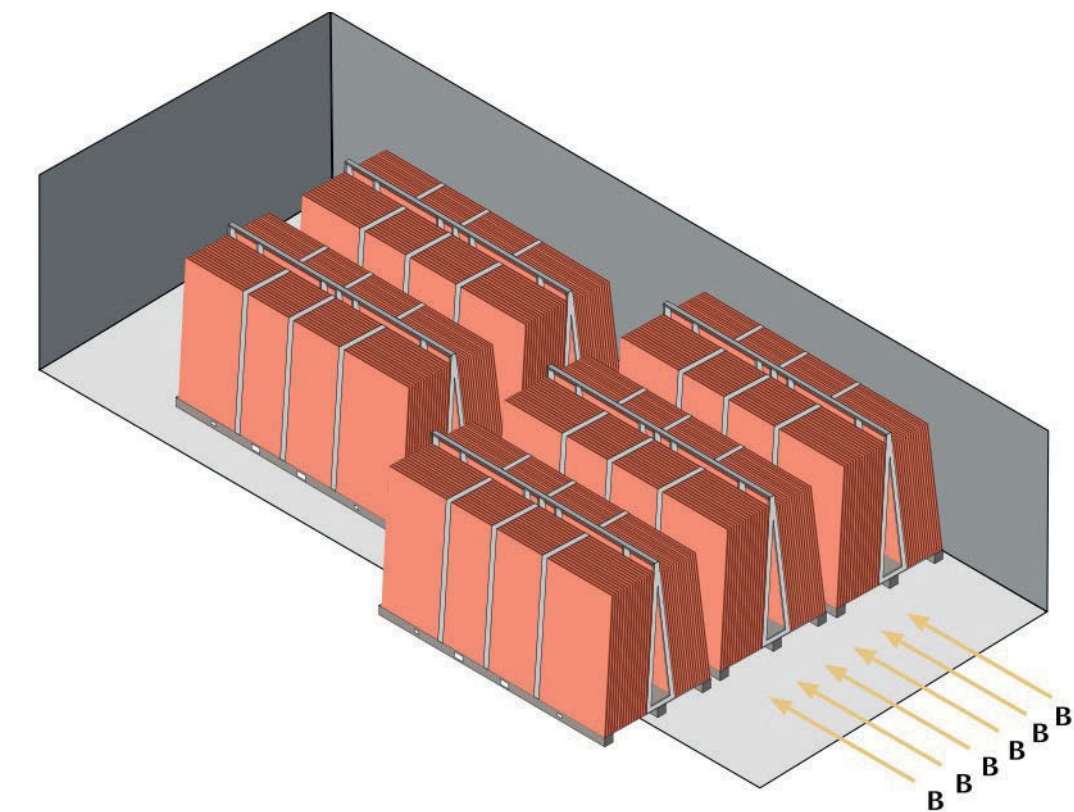

Packaging and Shipping Details / Kalesinterflex

1.1.3. Loading/Unloading Container With A-Frame

For loading/unloading the slabs, as seen in the picture below, a special lifting tool with belts, which is installed on a forklift having a load capacity of 5000-8000 kg. should be used. On the other hand, a crane equipped with a lifting arm, which is usually used to carry slabs, can be utilized.

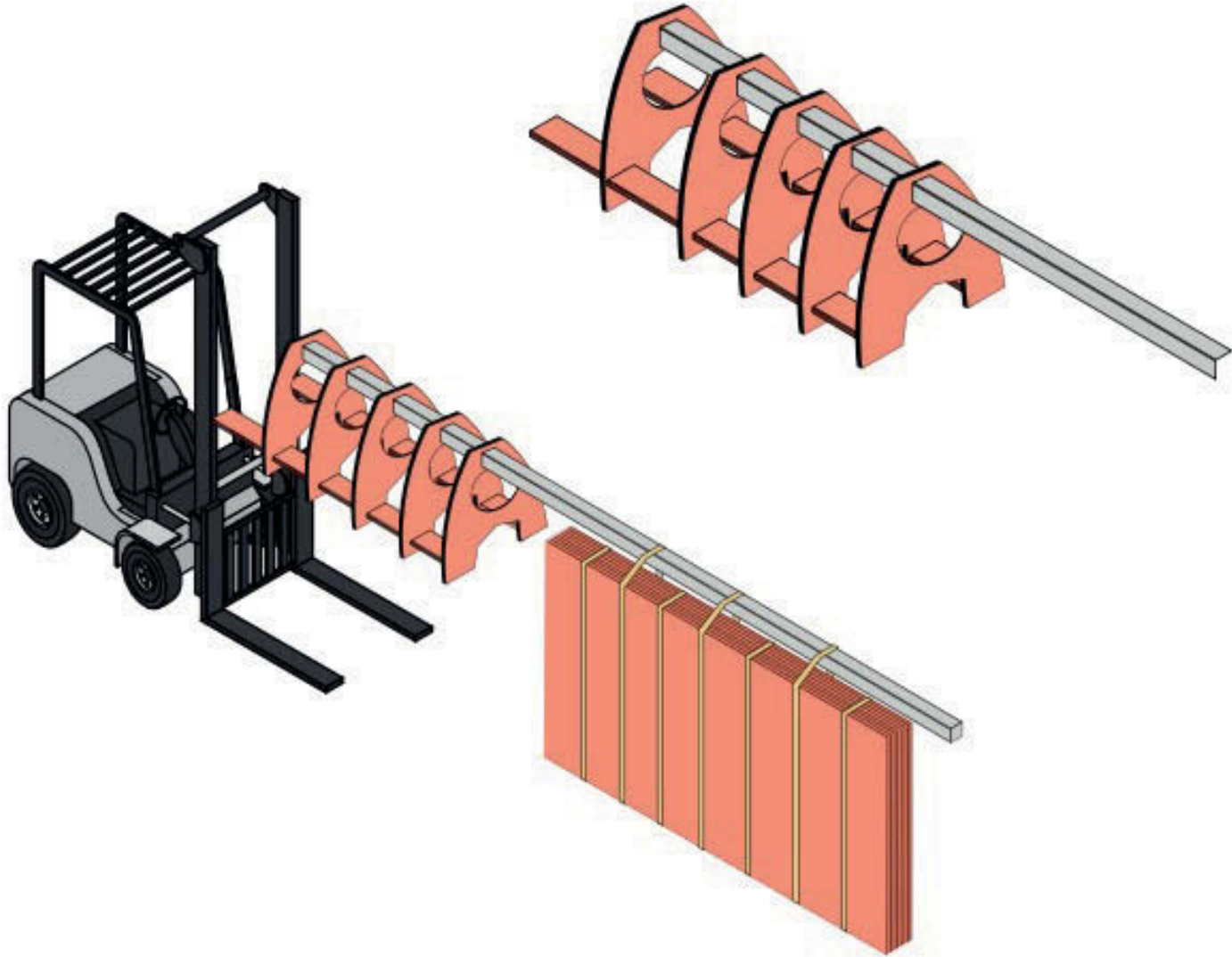

We recommend you use a similar tool and follow the same method to prevent imbalance and accidental damage during the unloading period.

Regardless of the method used for storing, other materials should not be put on Kalesinterflex slabs, especially on glossy surfaces.

If it is necessary to put them on top of each other, there should be no contact between the slabs. If the products are to be transferred from A-Frame to A-Frame one by one, precautions should be taken against surface damage that may occur.



Technical Characteristics / Kalesinterflex

KALESINTERFLEX SLAB 6 - 12 mm

	Norm- test method	Requirements for nominal size N		KALE 1620X3230 (mm) Non-rectified"		KALE 1600X3200R (mm) Rectified"		KALE 800X2800R (mm) Rectified"		KALE 800X3200R (mm) Rectified"	
		N≥15 cm		Matte	Polished	Matte	Polished	Matte	Polished	Matte	Polished
		% (for rectified)	mm (for rectified)								
Length and width	ISO 10545-2	± 0,3	± 1	N.A.	N.A.	Suitable	Suitable	Suitable	Suitable	Suitable	Suitable
		± 0,5	± 0,5	N.A.	N.A.	Suitable	Suitable	Suitable	Suitable	Suitable	Suitable
Straightness of sides		± 0,3	± 0,8	N.A.	N.A.	Suitable	Suitable	Suitable	Suitable	Suitable	Suitable
Rectangularity (Measurement only on short edges when L/l ≥ 3)		± 0,3	± 1,5	N.A.	N.A.	Suitable	Suitable	Suitable	Suitable	Suitable	Suitable
Surface flatness		c.c. ± 0,4	c.c. ± 1,8	N.A.	N.A.	Suitable	Suitable	Suitable	Suitable	Suitable	Suitable
		e.c. ± 0,4	e.c. ± 1,8	N.A.	N.A.						
		w. ± 0,4	w. ± 1,8	N.A.	N.A.						
Water absorption	ISO 10545-3	Ev ≤ 0,5% Individual max 0,6%		≤ 0,1 %	≤ 0,1 %	≤ 0,1 %	≤ 0,1 %	≤ 0,1 %	≤ 0,1 %	≤ 0,1 %	≤ 0,1 %
Breaking strength	ISO 10545-4	for thickness < 7,5mm S ≥ 700 N for thickness ≥ 7,5mm S ≥ 1300 N"		6 mm -> S ≥ 700N 12 mm -> S ≥ 4000N	6 mm -> S ≥ 700N 12 mm -> S ≥ 4000N	6 mm -> S ≥ 700N 12 mm -> S ≥ 4000N	6 mm -> S ≥ 700N 12 mm -> S ≥ 4000N	6 mm -> S ≥ 700N 12 mm -> S ≥ 4000N"	6 mm -> S ≥ 700N 12 mm -> S ≥ 4000N"	6 mm -> S ≥ 700N 12 mm -> S ≥ 4000N	6 mm -> S ≥ 700N 12 mm -> S ≥ 4000N
Modulus of rupture		R ≥ 35 N/mm ²		6 mm -> R ≥ 35 N/mm ² 12 mm -> R ≥ 45 N/mm ²	6 mm -> R ≥ 35 N/mm ² 12 mm -> R ≥ 45 N/mm ²	6 mm -> R ≥ 35 N/mm ² 12 mm -> R ≥ 45 N/mm ²	6 mm -> R ≥ 35 N/mm ² 12 mm -> R ≥ 45 N/mm ²	6 mm -> R ≥ 35 N/mm ² 12 mm -> R ≥ 45 N/mm ²	6 mm -> R ≥ 35 N/mm ² 12 mm -> R ≥ 45 N/mm ²	6 mm -> R ≥ 35 N/mm ² 12 mm -> R ≥ 45 N/mm ²	6 mm -> R ≥ 35 N/mm ² 12 mm -> R ≥ 45 N/mm ²
Impact resistance, as coefficient of restitution	ISO 10545-5	Declared value		≥ 55	≥ 55	≥ 55	≥ 55	≥ 55	≥ 55	≥ 55	≥ 55
Resistance to deep abrasion of unglazed tiles (removed volume)	ISO 10545-6	≤ 175 mm ³		Suitable	Suitable	Suitable	Suitable	Suitable	Suitable	Suitable	Suitable
Coefficient of thermal linear expansion	ISO 10545-8	Declared value		≤ 7 MK-1	≤ 7 MK-1	≤ 7 MK-1	≤ 7 MK-1	≤ 7 MK-1	≤ 7 MK-1	≤ 7 MK-1	≤ 7 MK-1
Thermal shock resistance	ISO 10545-9	Pass according to EN ISO 10545-1		Resistant	Resistant	Resistant	Resistant	Resistant	Resistant	Resistant	Resistant
Moisture expansion (in mm/m)	ISO 10545-10	Declared value		≤ 0,01% (0,1mm/m)	≤ 0,01% (0,1mm/m)	≤ 0,01% (0,1mm/m)	≤ 0,01% (0,1mm/m)	≤ 0,01% (0,1mm/m)	≤ 0,01% (0,1mm/m)	≤ 0,01% (0,1mm/m)	≤ 0,01% (0,1mm/m)
Frost resistance	ISO 10545-12	Pass according to EN ISO 10545-1		Resistant	Resistant	Resistant	Resistant	Resistant	Resistant	Resistant	Resistant
Bond strength/adhesion for improved cementitious adhesives	EN 1348	Declared value		≥ 0,5 N/mm ²	≥ 0,5 N/mm ²	≥ 0,5 N/mm ²	≥ 0,5 N/mm ²	≥ 0,5 N/mm ²	≥ 0,5 N/mm ²	≥ 0,5 N/mm ²	≥ 0,5 N/mm ²
Reaction to fire	-	A1 or AfI		A1 without fiberglass	A1 without fiberglass	A1 without fiberglass	A1 without fiberglass	A1 without fiberglass	A1 without fiberglass	A1 without fiberglass	A1 without fiberglass
Resistance to household chemicals and swimming pool salts		Minimum Class B		A	A	A	A	A	A	A	A
Resistance to low concentrations of acids and alkalis	ISO 10545-13	Declared value		LA	LA	LA	LA	LA	LA	LA	LA
Resistance to high concentrations of acids and alkalis		Declared value		HA	-	HA	-	HA	-	HA	-
Resistance to staining	ISO 10545-14	Declared value		5	5	5	5	5	5	5	5
Release of dangerous substances: Cadmium (in mg/dm²) and Lead (in mg/dm²)	ISO 10545-15	Declared value		≤ 0,01 mg/dm ² Cd ≤ 0,1 mg/dm ² Pb"	≤ 0,01 mg/dm ² Cd ≤ 0,1 mg/dm ² Pb	≤ 0,01 mg/dm ² Cd ≤ 0,1 mg/dm ² Pb"	≤ 0,01 mg/dm ² Cd ≤ 0,1 mg/dm ² Pb"	≤ 0,01 mg/dm ² Cd ≤ 0,1 mg/dm ² Pb	≤ 0,01 mg/dm ² Cd ≤ 0,1 mg/dm ² Pb	≤ 0,01 mg/dm ² Cd ≤ 0,1 mg/dm ² Pb	

Technical Characteristics / Kalesinterflex

KALESINTERFLEX SLAB 3 mm

	Norm - test method	Requirements for nominal size N		KALE 1000X3000R (mm) Rectified		KALE 1200X3600R (mm) Rectified	
		N≥15 cm		Matte	Polished	Matte	Polished
		% (for rectified)	mm (for rectified)				
Length and width	ISO 10545-2	± 0,3	± 1	Suitable	Suitable	Suitable	Suitable
Thickness		± 0,5	± 0,5	Suitable	Suitable	Suitable	Suitable
Straightness of sides		± 0,3	± 0,8	Suitable	Suitable	Suitable	Suitable
Rectangularity (Measurement only on short edges when L/l ≥ 3)		± 0,3	± 1,5	Suitable	Suitable	Suitable	Suitable
Surface flatness		c.c. ± 0,4	c.c. ± 1,8	Suitable	Suitable	Suitable	Suitable
		e.c. ± 0,4	e.c. ± 1,8				
	w. ± 0,4	w. ± 1,8					
Water absorption	ISO 10545-3	Ev ≤ 0,5% Individual max 0,6%		≤ 0,3 %	≤ 0,3 %	≤ 0,3 %	≤ 0,3 %
Modulus of rupture	ISO 10545-4	R ≥ 35 N/mm ²		3 mm -> R ≥ 45 N/mm ²	3 mm -> R ≥ 45 N/mm ²	3 mm -> R ≥ 45 N/mm ²	3 mm -> R ≥ 45 N/mm ²
Impact resistance, as coefficient of restitution		Declared value		≥ 55	≥ 55	≥ 55	≥ 55
Resistance to deep abrasion of unglazed tiles (removed volume)	ISO 10545-6	≤ 175 mm ³		Suitable	Suitable	Suitable	Suitable
Coefficient of thermal linear expansion	ISO 10545-8	Declared value		≤ 7 MK-1	≤ 7 MK-1	≤ 7 MK-1	≤ 7 MK-1
Thermal shock resistance	ISO 10545-9	Pass according to EN ISO 10545-1		Resistant	Resistant	Resistant	Resistant
Moisture expansion (in mm/m)	ISO 10545-10	Declared value		≤ 0,01% (0,1mm/m)	≤ 0,01% (0,1mm/m)	≤ 0,01% (0,1mm/m)	≤ 0,01% (0,1mm/m)
Frost resistance	ISO 10545-12	Pass according to EN ISO 10545-1		Resistant	Resistant	Resistant	Resistant
Bond strength/adhesion for improved cementitious adhesives	EN 1348	Declared value		≥ 0,5 N/mm ²	≥ 0,5 N/mm ²	≥ 0,5 N/mm ²	≥ 0,5 N/mm ²
Reaction to fire	-	A1 or AfI		A1 without fiberglass	A1 without fiberglass	A1 without fiberglass	A1 without fiberglass
Resistance to household chemicals and swimming pool salts	ISO 10545-13	Minimum Class B		A	A	A	A
Resistance to low concentrations of acids and alkalis		Declared value		LA	LA	LA	LA
Resistance to high concentrations of acids and alkalis		Declared value		HA	-	HA	-
Resistance to staining		Declared value		5	5	5	5
Release of dangerous substances: Cadmium (in mg/dm ²) and Lead (in mg/dm ²)	ISO 10545-15	Declared value		≤ 0,01 mg/dm ² Cd ≤ 0,1 mg/dm ² Pb	≤ 0,01 mg/dm ² Cd ≤ 0,1 mg/dm ² Pb	≤ 0,01 mg/dm ² Cd ≤ 0,1 mg/dm ² Pb	≤ 0,01 mg/dm ² Cd ≤ 0,1 mg/dm ² Pb



INDEX



A COMPLETE
PRODUCT
SYSTEM



PRODUCT
FINDER



LOOK



COMPANY



KALESINTERFLEX



T-ONE



TECHNICAL
SPECIFICATIONS

Symbols / T-One



LOW WATER ABSORPTION
(NEAR ZERO)



HYGIENIC



NON-FLAMMABLE
(FLAME RESISTANT)



EVERLASTING



EASE OF
CLEANING



RESISTANT TO
HOUSEHOLD
CLEANING
MATERIALS



HIGH
SCRATCH
RESISTANCE

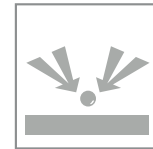

HIGH
BREAKING
STRENGTH



HIGH STAIN
RESISTANCE



HIGH HEAT
AND FROST
RESISTANCE

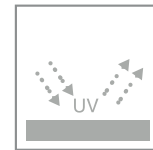

HIGH RESISTANCE
TO UV RAYS



HIGH RESISTANCE
TO UV RAYS



*Not valid for glossy product.



Technical Specifications / T-One

INDEX

A COMPLETE
PRODUCT
SYSTEM

PRODUCT
FINDER

LOOK

COMPANY

KALESINTERFLEX

T-ONE

TECHNICAL
SPECIFICATIONS

ISO	Technical Specifications	T-One MATTE 1620x3240x12 mm	T-One POLISHED 1620x3240x12 mm
	Weight kg/m ²	30	30
ISO 10545-2	Surface Quality	>95	>95
ISO 10545-3	Water Absorption	E 0,1 %	E 0,1 %
ISO 10545-4	Breaking Strength (N)	> 400 N	> 400 N
	Modules of Rupture (N/mm ²) Sample size: 400x800 mm	Average 50 N/mm ²	Average 50 N/mm ²
ISO 10545-6	Resistance to Deep abrasion-Unglazed Tiles Only	175 mm ³	175 mm ³
ISO 10545-8	Linear Thermal Expansion Coefficient	6,6 E-0,6	6,6 E-0,6
ISO 10545-9	Resistance to Thermal Shock	RESISTANT	RESISTANT
ISO 10545-12	Frost Resistance	RESISTANT	RESISTANT
ISO 10545-13	Resistance to Chemical	Class A to B	Class A to C
ISO 10545-14	Resistance to Staining	Class 4 to 5	Class 2 to 5

 **Kale**

Kaleseramik, Çanakkale Kalebodur Seramik San. A.Ş.
Büyükdere Cad. Kaleseramik Binası 34330 Levent - İstanbul / Turkey

kale.com.tr